



SYSTEMS, INC.

4X4 INSTALLATION MANUAL

CB-1000

CB-2000

CB-3000

PRELIMINARY

EFC Systems, Inc.

1325 Post Road

Havre de Grace, MD 21078

Copyright 1999-2004 All rights reserved. This document is subject to change.

Contents

Contents	2
Table of Figures	2
Description	3
Installation	4
External Connections	5
UP-100 / UP-200 / UP-500 / PS-100	5
TSC-400	6
AFC-400	7
FRC-200	8
4x4 Back Panel Terminals	9
UP-100 / UP-200 / UP-500 / PS-100	9
TSC-400 Turbine Speed Controller	10
AFC-400 Air Flow Controller	12
Card Cage Connectors	16
4X4 UP-100 / UP-500/ PS-100	16
4X4 TSC-400 / AFC-400 / FRC-200	17
Cabinet Layout	18
Inside Cabinet User Connection Area View	18
Circuit Schematics	19
Change Log	39

Table of Figures

Figure 1: UP-x00 Enable Circuit	19
Figure 2: UP-x00 and PS-100 Enable Feedback Circuit	20
Figure 3: UP-x00 and PS-100 Cascade Interface	21
Figure 4: UP-x00 Fault Circuit	22
Figure 5: UP-x00 Analog Voltage Control Input	23
Figure 6: UP-x00 Analog (4-20mA) Voltage Control	24
Figure 7: UP-x00 Hi/Lo Voltage Control	25
Figure 8: UP-100 Analog (4-20mA) Feedback Circuits	26
Figure 9: UP-200/500 Analog (4-20mA) Feedback Circuits	27
Figure 10: TSC-400 and AFC-400 Enable Circuit	28
Figure 11: TSC-400 and AFC-400 Proportional Pressure Transducer Interface	29
Figure 12: TSC-400 and AFC-400 Analog Speed/Pressure Feedback Interface	30
Figure 13: TSC-400 Microphone Interface	31
Figure 14: TSC-400 Fiber Optic Interface	32
Figure 15: TSC-400 Brake Air Interface	33
Figure 16: TSC-400 and AFC-400 Analog Voltage Control Interface	34
Figure 17: TSC-400 and AFC-400 Analog Current Control Input	35
Figure 18: TSC-400 Fault Relay Interface	36
Figure 19: AFC-400 Air Flow Meter and RS422 Converter	37
Figure 20: AFC-400 Shaping Air Return Monitor Circuit	38

Description

The EFC 4x4 Card cage is a pre-wired system that supports the PS-100, UP-100, UP-200, UP-500, TSC-400, FRC-200, and AFC-400 products from EFC. The card cage and back plane can be designed to handle the following configurations:

- CB-1000 (Four UP-100/200/500s) or (Four PS-100s)
- CB-2000 (Four UP-100/200/500s, One TSC-400 / AFC-400 / FRC-200)
- CB-3000 (Four UP-100/200/500s, Two TSC-400 /AFC-400 / FRC-200)
- CB-4000 (Six UP-100/200/500s)
- CB-5000 (Six TSC-400 / AFC-400 / FRC-200)

This card cage is intended for professional installation, by qualified personnel who are familiar with the installation of electrostatic power systems.

PRELIMINARY

Installation

As described in section 1 the 4x4 can be configured in several configurations. To the installer there are four basic interfaces that need to be dealt with. All of the required wires for operation from the various devices in the card cage are brought to the rear hook-up area for interfacing to the other parts of the system. This makes the connection point in the card cage a fixed location and the connecting cables easy to replace in case of a wire breakage.

The following is a detailed Installation procedure, depending on the installation, not all steps are necessary.

1. Position the base unit on the wall or mounting rack where the installation will be made. Be sure that the surface can hold the weight of the rack and the power supplies that will be placed into it. If needed, provide a supporting shelf to the underside of the cabinet.
2. Install four mounting bolts (not included) and secure the base unit.
3. The 4x4 rack system does not come with a power cord attached, it is intended that a conduit with 120V AC power be brought into the unit.
4. Run in the power wires and attach them to the power connectors located on the lower right of the cabinet as follows:
 - Black (Power Main) to screw block 1A
 - White (Power Neutral) to screw block 2A
 - Green (ground) to screw block 6A

DO NOT APPLY POWER AT THIS TIME.

5. Identify each board mounted on the back panel and connect the control signals to the screw terminals as needed (see Appendix A for details of each board).
6. Close back panel of card cage and lock with the included key.
7. Install Power Supplies and Control Units into the card cage, each device type is labeled on the back plane as you look into the front of the rack. Each slot is set up to support only that type of device. A Control Unit that is placed into the wrong slot will not receive power and thus not operate.
8. Enable power and test.

External Connections

Refer to Figure 1, 2, 3 for typical installation for each of the Control Units. Connect the wires from this point to the Controller, High Voltage Generator, Interlock Switches, etc. For details on these signals refer to the associated Service and Operations Manual for each unit.

UP-100 / UP-200 / UP-500 / PS-100

The following notes are critical for proper operation of the UP-100, UP-200, UP-500, and PS-100.

1. Use pins 1 and 2 with a relay in the controller to enable and disable the power supply. Pin 2 is ground and pin 1 is connected to one side of a relay coil in the power supply. The other side of the coil is connected to 24V (PS100) and 12V (UP-100). Simply shorting these two pins together will enable the supply assuming other signals explained below are connected correctly.
2. Pins 3 supplies a 4-20ma feedback signal in reference to the current meter. Use this in reference to pin 5 (ground).
3. Pin 4 supplies a 4-20ma feedback in reference to the voltmeter. Use this in reference to pin 5 (ground).
4. Pins 8, 9, 10 provide feedback as to the status of Fault Relay 2. In normal operation pin 10 (NC) and pin 9 (Common) are closed, when a fault happens these pins will open. Similarly pin 8 (NO) and pin 9 (Common) will be open and in a fault condition they will close. These pins are isolated contact closures.
5. Pins 11,12,13 provide feedback as to the status of the enable relay. In normal operation pin 12 (NO) and 13 (Common) are closed when the power supply is enabled. and opened when the power supply is disabled. Similarly pins 11 (NC) and 13 (Common) are open when the power supply is enabled and closed when disabled. These pins are isolated contact closures.
6. Pins 14, 15, 16 provide feedback as to the status of Fault Relay 1. In normal operation pin 15 (NC) and pin 14 (Common) are closed, when a fault happens these pins will open. Similarly pin 16 (NO) and pin 14 (Common) will be open and in a fault condition they will close. These pins are isolated contact closures.
7. Pins 17 and 7 provide the method of controlling the power supply in HI/LO mode. A short between these pins will place the power supply in "HI" mode, whereas an open will place the power supply in "LO" mode.
8. Pins 18 and 6 provide the method of controlling the power supply in remote analog voltage mode. A signal of 0-10 volts on pin 18 with respect to pin 6 will correspond to 0 to 100KV. If used Pin 19 must be not connected.
9. Pins 19 and 6 provide the method of controlling the power supply in remote analog current mode. This places a 50 - 200 ohm resistor in the circuit. A current of 0ma will yield 0KV and a current of 20ma will yield 100KV. If used Pin 18 must be not connected.
10. Pins 20 and 21 provide feedback as to the status of the power supply, either in local or remote mode. A contact closer indicates Remote mode, whereas a open circuit indicates Local mode.

11. Pins 22 and 23 provide inputs for the conveyer interlock switch 1 and pin 24 and 25 provide inputs for interlock switch 2. **If either of these is not used, they must be jumped closed in order for the power supply to enable.**
12. The High Voltage Generator is connected to the pins labeled B W R S. A special cable as noted on the drawing in figure 1 should be used from this point to the end of the robot arm. The pin connections at the high voltage generator must match the following.
 - B - Black - Cascade Pin C
 - W - White - Cascade Pin B
 - R - Red - Cascade Pin A
 - S - Shield - this must be connected all the way to the robot arm. It is not connected at the robot arm end. It is only connected at the card cage (this point). If this wire is spliced it is important to connect the shield past the splice.

Special Note: The Low Voltage Wire connected to Terminals BWRS must be Belden 3 Wire, 18AWG with shield, EFC P/N 428Q70. The shield is only connected to ground at the power supply (cabinet) side, and must be connected all the way to the Cascade.

TSC-400

The following notes are critical for proper operation of the TSC- 400.

Because the TSC-400 has four identical interfaces, Channel “A” is explained below, use the pin chart to connect the other three channels. The four channels are labeled A, B, C, D and relate directly to the front panel and software mnemonics. Refer to the TSC-400 pinout table on page 10.

1. Use pins 16A and 19A for the Stop/Enable signal, Pin 16A is a 0 or 5 to 24V input with respect to pin 19A (Ground). **Caution** this input operates differently depending which mode is selected. Refer to the TSC-400 manual for more detail.
2. Pins 11A and 12A are used for the microphone or fiber optic input. Pin 11A is the input with respect to pin 12A (Ground). A +24V is available on pin 10A for powering the fiber optic unit if used. It is recommended that a shielded cable be used for the Microphone input. The shield can be attached to 12A with the ground.
3. Pins 4A and 5A are used for control of the external Proportional Valve. This output is a 4-20mA interface. The Proportional Valve must utilize a 4-20mA interface also. Pin 4A is the positive output source pin and pin 5A is ground. This utilizes the onboard 24V power supply for current. Refer to the TSC-400 manual for more detail.
4. Pins 1A, 2A, 3A are connected to the relay 1. This is an independent interface with Pin 2A as the Common, Pin 1A as the Normally Open connection, Pin 3A is the Normally Closed connection. This can be used for several options. Refer to the TSC-400 manual for more detail.
5. Pin 6A and 7A form the analog current input. Pin 6A is the active pin, where pin 7A is ground. This is where the 0-20mA or 4-20mA or 0-5V interface is installed. The calibration of this interface works in conjunction with the Max Turbine Speed setting in the software. Changing this setting will change the calibration of this interface.

6. Pin 8A and Pin 9A form the analog 4-20mA speed feedback. Pin 8A is the active pin, where pin 9A is ground. This is where the 4-20mA feedback interface is installed. The calibration of this interface works in conjunction with the Max Turbine Speed setting in the software. Changing this setting will change the calibration of this interface.
7. Pin 13A, 14A, 15A are the output for the second relay. This can be used as a channel ready, brake relay, fault relay. See the TSC-400 manual for more detail. 14A is the common pin, 13A is normally open, 15A is normally closed.

AFC-400

Because the AFC-400 has four identical interfaces, only Channel “A” is explained below. The four channels are labeled A, B, C, D and relate directly to the front panel and software mnemonics. Refer the AFC pinout on page 12.

1. Use pins 16A and 19A for the Stop/Enable signal. Pin 16A is a 0 or 5 to 24V input with respect to pin 19A (Ground). **Caution** this input operates differently depending which mode is selected. Refer to the AFC-400 manual for more detail.
2. Use pins 21A and 20A as the RS422 inputs from the mass air flow sensors. The Universal or Alicat flow rate and pressure sensors have RS232 interfaces that are converted to RS422 (differential signaling) using an interface converter (EFC P/N 90-4A12).
3. Pins 4A and 5A are used for control of the external pressure transducer or proportional valve. This output is a 4-20mA analog control interface, used by the AFC-400 to adjust flow rate and pressure. Pin 4A is the positive output source pin and pin 5A is ground. This utilizes the onboard 24V power supply for current. Refer to the AFC-400 manual for more detail.
4. Pins 1A, 2A, 3A are connected to the relay 1. This is an independent interface with Pin 2A as the Common, Pin 1A as the Normally Open connection, Pin 3A is the Normally Closed connection. This can be used for several options. Refer to the AFC-400 manual for more detail.
5. Pin 6A and 7A form the analog current input. Pin 6A is the active pin, where pin 7A is ground. This is where the 0-20 mA or 4-20 mA or 0-5 volts interface is installed. The scaling of this interface works in conjunction with the Max Pressure software setting.
6. Pin 8A and Pin 9A form the analog 4-20mA pressure feedback. Pin 8A is the active pin, where pin 9A is ground. This is where the 4-20mA feedback interface is installed. The scaling of this interface works in conjunction with the Max Pressure setting in the software so that the feedback is 4mA at ambient pressure, and 20mA at Maximum Pressure.
7. Pin 13A, 14A, 15A are the output for the second relay. This can be used as a channel ready, or fault relay. See the AFC-400 manual for more detail. 14A is the common pin, 13A is normally open, 15A is normally closed.
8. Pin 22A and 5E are used to provide an analog input (4-20ma) from an Ashcroft ASH-K1-7-M02-42-F2 pressure transducer. This allows the AFC-400 to monitor the pressure inside the air manifold of the atomizer. See figure **Error! Reference source not found.**, in the appendices for more detail as to the connections.

FRC-200

The FRC-200 has two channels that are connected to the same back panel card that is used for the TSC-400 and AFC-400. Channel A on the FRC-200 generally connects to sections A and B on the back panel board and the Channel B connects to sections C and D on the back panel board.

PRELIMINARY

4x4 Back Panel Terminals

UP-100 / UP-200 / UP-500 / PS-100

4x4 Terminal	UP-200 Connectors	Description
1	Az2	Remote HV Enable input
2	Ab2	Remote HV Enable (Ground)
3	Bd6	Current meter feedback signal (4-20mA)
4	Bd8	Volt meter feedback signal (4-20mA)
5	Bz6	Volt/Current feedback common (Ground)
8	Ad16	Fault Relay 2 (NO contact)
9	Ad14	Fault Relay 2 (Common contact)
10	Ad18	Fault Relay 2 (NC contact)
11	Ad6	Enable Relay Feedback – (NC contact)
13	Ad2	Enable Relay Feedback – (Common)
12	Ad4	Enable Relay Feedback – (NO contact)
B	Ad8	Cascade Feedback (Black)
W	Ab8	Cascade 0 to -21 Volts (White)
R	Az8	Cascade Ground (Red)
S	Az32	Cascade LV Cable Shield (Shield)
14	Az16	Fault Relay 1 (Common contact)
15	Ad12	Fault Relay 1 (NC contact)
16	Ad10	Fault Relay 1 (NO contact)
17	Bd12	Hi/Lo Control Input
7	Bb12	Hi/Lo Common (Ground)
18	Bz10	Voltage Control Input*
19	Bz12	Current Control Input*
6	Bd10	Volt/Current common (Ground)
20	Bd14	Local/Remote Switch +
21	Bd16	Local/Remote Switch -
22	Bz2	Enable Interlock 1 +
23	Bd2	Enable Interlock 1 -
24	Bz4	Enable Interlock 2 +
25	Bd4	Enable Interlock 2 -
DB9(1)	Ab26	(RS422)
DB9(2)	Ab28	(RS422)
DB9(4)	Ab30	(RS422)
DB9(5)	Ab32	(RS422)

* Connect / Use only one, the other signal must float.

Please note that the Voltage and Current feedback signals on version 5 and earlier models of the UP-100 work differently from those on the UP-200/500. The UP-100 used a 4-20mA sinking interface that required an external power supply (see diagram in Appendix) and the UP-200/500 uses a 4-20mA sourcing interface. Version 6 and later of the UP-100 have been changed to provide the sourcing interface.

TSC-400 Turbine Speed Controller

TSC-400 Connectors	4x4 Back panel Terminal	Description
Channel A		
A1	1A	Relay A1 NO
B1	2A	Relay A1 COM
C1	3A	Relay A1 NC
A2	4A	Proportional Valve Control A +
B2	8A	Feedback A +
C2	6A	Analog In A +
A3	5A	Proportional Valve Control A-
B3	9A	Feedback A -
C3	7A	Analog In A -
A4	10A	Counter Input A + 24V
B4	11A	Counter Input A+
C4	12A	Counter Input A-
A5	13A	Relay A2 NO
B5	14A	Relay A2 COM
C5	15A	Relay A2 NC
A6	16A	Input A1 (0-5 to 24V)
B6	18A	Input A2 (0-5 to 24V)
C6	19A	Input A COMMON
A7	NC	+24V
B7	21A	Not Used
C7	22A	Not Used
A8	17A	Ground
B8	20A	Ground
C8	23A	Ground
Channel B		
A9	1B	Relay B1 NO
B9	2B	Relay B1COM
C9	3B	Relay B1 NC
A10	4B	Proportional Valve Control B +
B10	8B	Feedback B +
C10	6B	Analog In B +
A11	5B	Proportional Valve Control B-
B11	9B	Feedback B -
C11	7B	Analog In B -
A12	10B	Counter Input B + 24V
B12	11B	Counter Input B +
C12	12B	Counter Input B -
A13	13B	Relay B2 NO
B13	14B	Relay B2 COM
C13	15B	Relay B2 NC
A14	16B	Input B1 (0-5 to 24V)
B14	18B	Input B2 (0-5 to 24V)

PRELIMINARY

TSC-400 Connectors	4x4 Back panel Terminal	Description
C14	19B	Input B COMMON
A15	NC	+24V
B15	21B	Not Used
C15	22B	Not used
A16	17B	Ground
B16	20B	Ground
C16	23B	Ground
Channel C		
A17	1C	Relay C1 NO
B17	2C	Relay C1 COM
C17	3C	Relay C1 NC
A18	4C	Proportional Valve Control C +
B18	8C	Feedback C +
C18	6C	Analog In C +
A19	5C	Proportional Valve Control C-
B19	9C	Feedback C -
C19	7C	Analog In C -
A20	10C	Counter Input C +24V
B20	11C	Counter Input C +
C20	12C	Counter Input C -
A21	13C	Relay C2 NO
B21	14C	Relay C2 COM
C21	15C	Relay C3 NC
A22	16C	Input C1 (0-5 to 24V)
B22	18C	Input C2 (0-5 to 24V)
C22	19C	Input C COMMON
A23	NC	+24V
B23	21C	Not used
C23	22C	Not used
A24	17C	Ground
B24	20C	Ground
C24	23C	Ground
Channel D		
A25	1D	Relay D1 NO
B25	2D	Relay D1 COM
C25	3D	Relay D1 NC
A26	4D	Proportional Valve Control D +
B26	8D	Feedback D +
C26	6D	Analog In D+
A27	5D	Proportional Valve Control D-
B27	9D	Feedback D -
C27	7D	Analog In D -
A28	10D	Counter Input D +24V
B28	11D	Counter Input D +
C28	12D	Counter Input D -

PRELIMINARY

TSC-400 Connectors	4x4 Back panel Terminal	Description
A29	13D	Relay D2 NO
B29	14D	Relay D2 COM
C29	15D	Relay D2 NC
A30	16D	Input D1 (0-5 to 24V)
B30	18D	Input D2 (0-5 to 24V)
C30	19D	Input D Common
A31	NC	+24V
B31	21D	Not Used
C31	22D	Not Used
A32	17D	Ground
B32	20D	Ground
C32	23D	Ground
Miscellaneous Connections		
	1E	RS422 TERMINAL RX +
	2E	RS422 TERMINAL RX -
	3E	RS422 TERMINAL TX +
	4E	RS422 TERMINAL TX -
	5E	+24V
	6E	+24V
	7E	+24V
	8E	+24V
	9E	GROUND
	10E	GROUND
	11E	GROUND
	12E	GROUND

AFC-400 Air Flow Controller

AFC-400	Connector	4x4 Terminal	Description
Channel A			
A1	J3(1)	1A	Relay A1 NO
B1	J3(14)	2A	Relay A1 COM
C1	J3(2)	3A	Relay A1 NC
A2	J3(3)	4A	Proportional Valve Control A +
B2	J3(4)	8A	Feedback A +
C2	J3(16)	6A	Analog In A1 +
A3	J3(15)	5A	Proportional Valve Control A-
B3	J3()	9A	Feedback A -
C3	J3()	7A	Analog In A1 -
A4	J3(5)	10A	+24VDC
B4	J3(17)	11A	Not Used
C4	J3(18)	12A	Ground
A5	J3(6)	13A	Relay A2 NO

AFC-400	Connector	4x4 Terminal	Description
B5	J3(19)	14A	Relay A2 COM
C5	J3(7)	15A	Relay A2 NC
A6	J3(8)	16A	Input Ch A 1 (0 - 5 to 24V)
B6	J3(21)	18A	Input Ch A 2 (0-5 to 24V)
C6	J3(20)	19A	Input Ch A Common
A7	NC	NC	+24VDC
B7	J3(9)	21A	RS422 RXA +
C7	J3(10)	22A	Analog In A2 +
A8	J3()	17A	Ground
B8	J3(22)	20A	RS422 RXA -
C8	J3(23)	23A	Analog In A2 -
Channel B			
A9	J7(1)	1B	Relay B1 NO
B9	J7(14)	2B	Relay B1 COM
C9	J7(2)	3B	Relay B1 NC
A10	J7(3)	4B	Proportional Valve Control B +
B10	J7(4)	8B	Feedback B +
C10	J7(16)	6B	Analog In B1 +
A11	J7(15)	5B	Proportional Valve Control B -
B11	J7()	9B	Feedback B -
C11	J7()	7B	Analog In B1 -
A12	J7(5)	10B	+24VDC
B12	J7(17)	11B	Not Used
C12	J7(18)	12B	Ground
A13	J7(6)	13B	Relay B2 NO
B13	J7(19)	14B	Relay B2 COM
C13	J7(7)	15B	Relay B2 NC
A14	J7(8)	16B	Input B1 (0 - 5 to 24V)
B14	J7(21)	18B	Input B2 (0 - 5 to 24V)
C14	J7(20)	19B	Input B Common
A15	NC	NC	+24VDC
B15	J7(9)	21B	RS422 RX B +
C15	J7(10)	22B	Analog In B2 +
A16	J7()	17B	Ground
B16	J7(22)	20B	RS422 RX B -
C16	J7(23)	23B	Analog In B2 -
Channel C			
A17	J8(1)	1C	Relay C1 NO
B17	J8(14)	2C	Relay C1 COM
C17	J8(2)	3C	Relay C1 NC
A18	J8(3)	4C	Proportional Valve Control C +
B18	J8(4)	8C	Feedback C +
C18	J8(16)	6C	Analog In C1 +
A19	J8(15)	5C	Proportional Valve Control C -
B19	J8()	9C	Feedback C -

AFC-400	Connector	4x4 Terminal	Description
C19	J8()	7C	Analog In C1 -
A20	J8(5)	10C	+24VDC
B20	J8(17)	11C	Not Used
C20	J8(18)	12C	Ground
A21	J8(6)	13C	Relay C2 NO
B21	J8(19)	14C	Relay C2 COM
C21	J8(7)	15C	Relay C2 NC
A22	J8(8)	16C	Input C1 (0-5 to 24V)
B22	J8(21)	18C	Input C2 (0-5 to 24V)
C22	J8(20)	19C	Input C Common
A23	NC	NC	+24VDC
B23	J8(9)	21C	RS422 RX C +
C23	J8(10)	22C	Analog In C2 +
A24	J8()	17C	Ground
B24	J8(22)	20C	RS422 RX C-
C24	J8(23)	23C	Analog In C2 -
Channel D			
A25	J9(1)	1D	Relay D1 NO
B25	J9(14)	2D	Relay D1 COM
C25	J9(2)	3D	Relay D1 NC
A26	J9(3)	4D	Proportional Valve Control D +
B26	J9(4)	8D	Feedback D +
C26	J9(16)	6D	Analog In D1 +
A27	J9(15)	5D	Proportional Valve Control D -
B27	J9()	9D	Feedback D -
C27	J9()	7D	Analog In D1 -
A28	J9(5)	10D	+24VDC
B28	J9(17)	11D	Not Used
C28	J9(18)	12D	Ground
A29	J9(6)	13D	Relay D2 NO
B29	J9(19)	14D	Relay D2 COM
C29	J9(7)	15D	Relay D2 NC
A30	J9(8)	16D	Input D1 (0-5 to 24V)
B30	J9(21)	18D	Input D2 (0-5 to 24V)
C30	J9(20)	19D	Input D Common
A31	NC	NC	+24VDC
B31	J9(9)	21D	RS422 RX D +
C31	J9(10)	22D	Analog In D2 +
A32	J9()	17D	Ground
B32	J9(22)	20D	RS422 RX D -
C32	J9(23)	23D	Analog In D2 -
Miscellaneous Connections			
		1E	RS422 TERMINAL RX+
		2E	RS422 TERMINAL RX-
		3E	RS422 TERMINAL TX+

PRELIMINARY

AFC-400	Connector	4x4 Terminal	Description
		4E	RS422 TERMINAL TX-
		5E	+24V
		6E	+24V
		7E	+24V
		8E	+24V
		9E	GROUND
		10E	GROUND
		11E	GROUND
		12E	GROUND

PRELIMINARY

Card Cage Connectors

4X4 UP-100 / UP-500/ PS-100

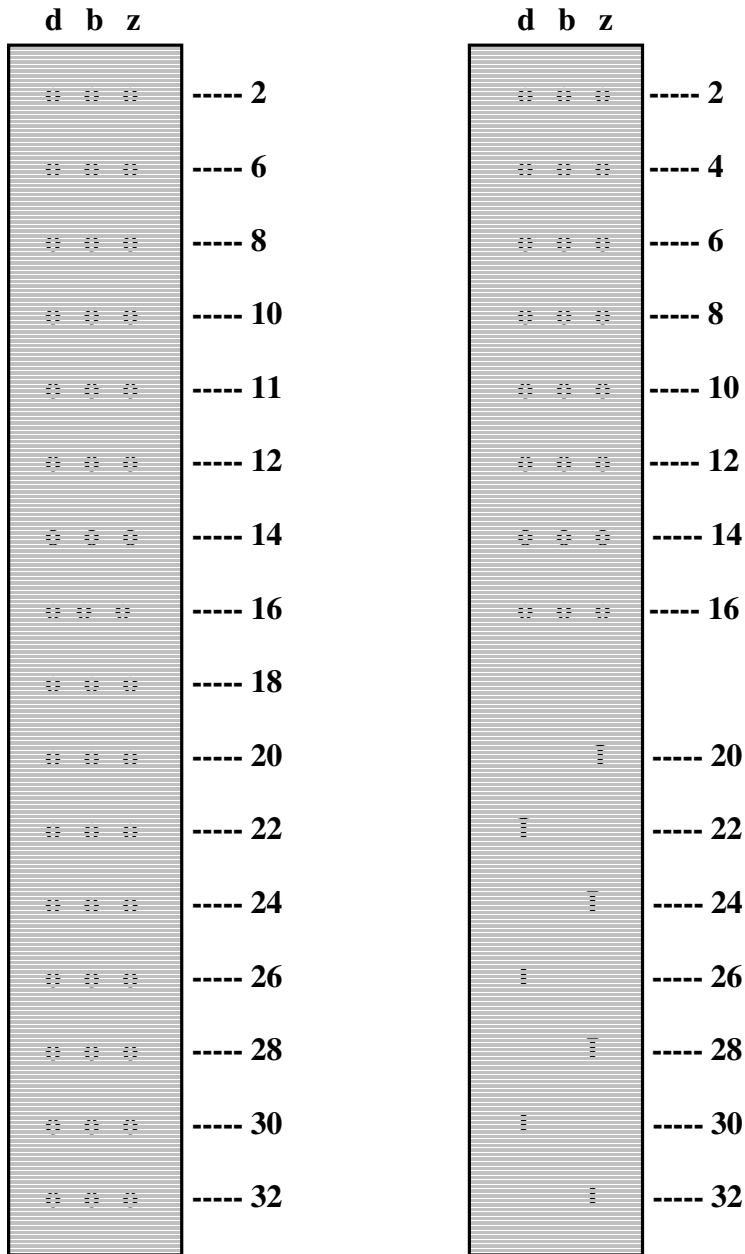

UP-100 / UP-500 / PS-100
Connector A (Rear View)
EFC P/N 60-1A69

UP-100 / UP-500 / PS-100 / QTSC / QFRC
Connector B (Rear View)
EFC P/N 60-1A70

PRELIMINARY

4X4 TSC-400 / AFC-400 / FRC-200

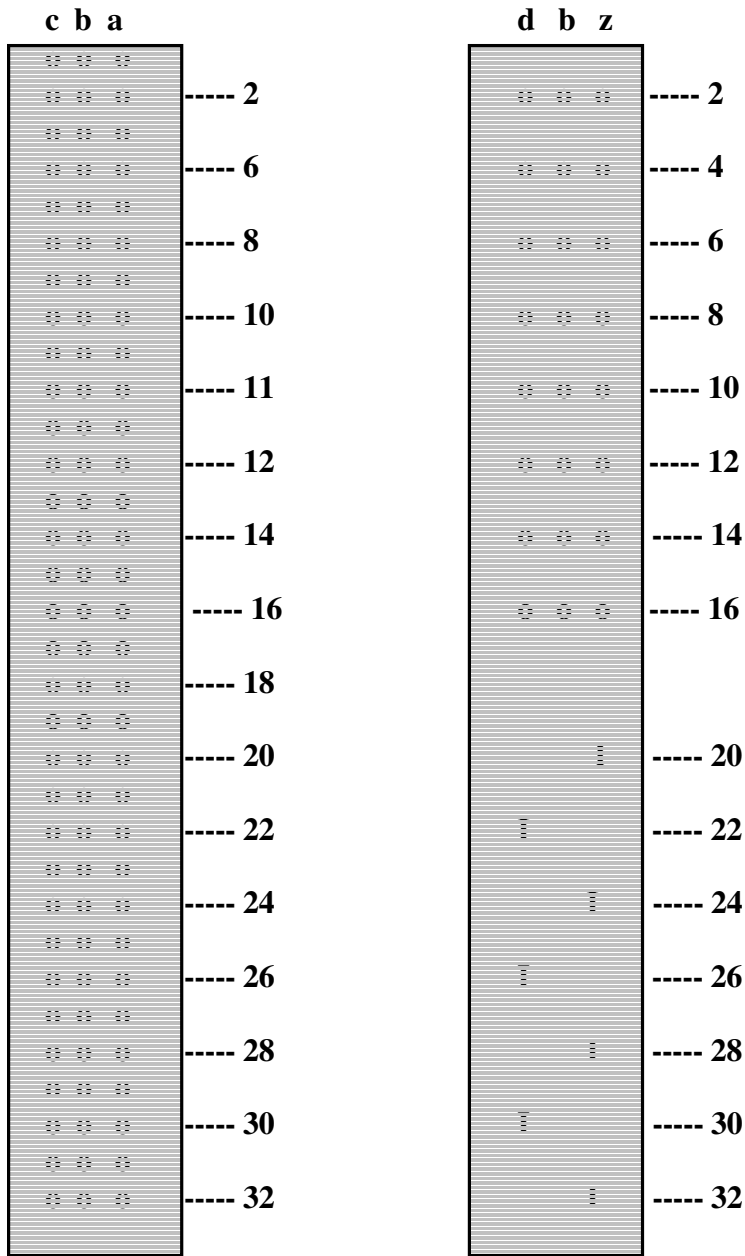

Top Connector
(Read View)

Bottom Connector
(Rear View)

PRELIMINARY

Cabinet Layout

Inside Cabinet User Connection Area View

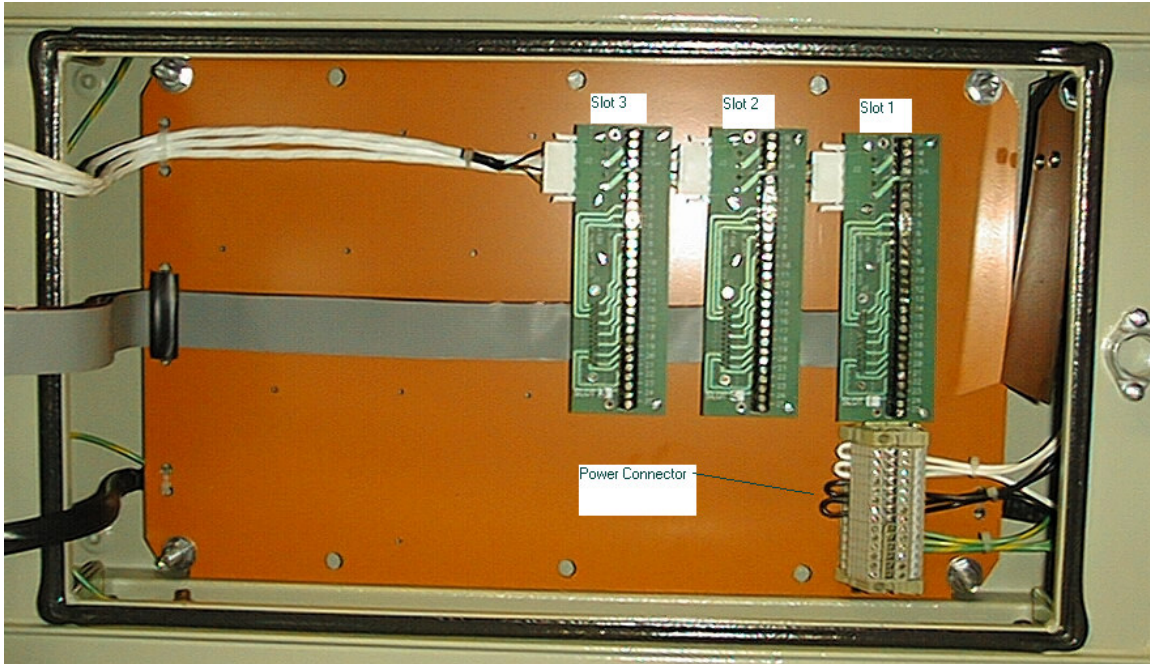

Note: Slot 1 (left hand side of the card cage) is connected to the interface board on the Right hand side of the back panel.

PRELIMINARY

Circuit Schematics

Figure 1: UP-x00 Enable Circuit

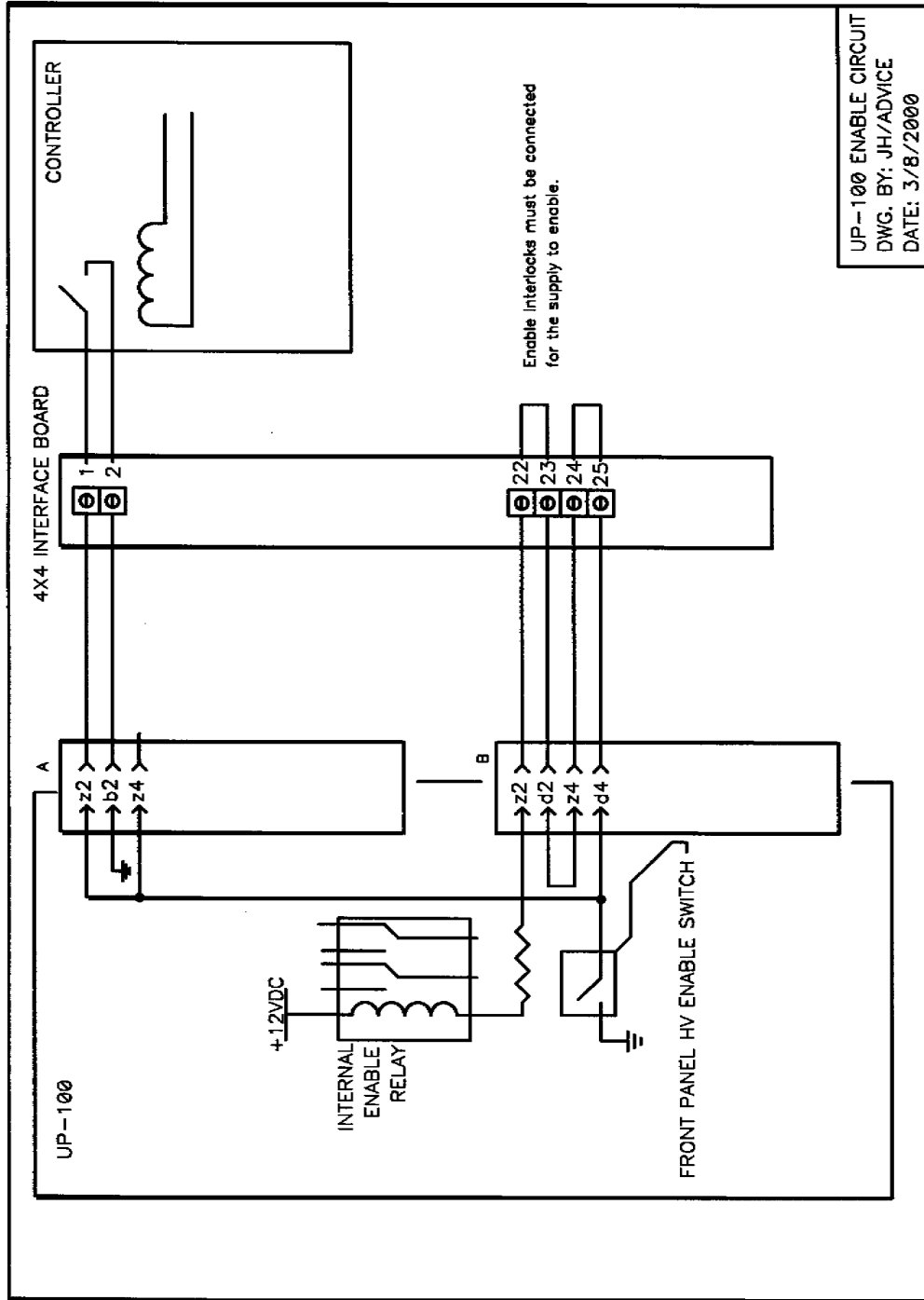

PRELIMINARY

Figure 2: UP-x00 and PS-100 Enable Feedback Circuit

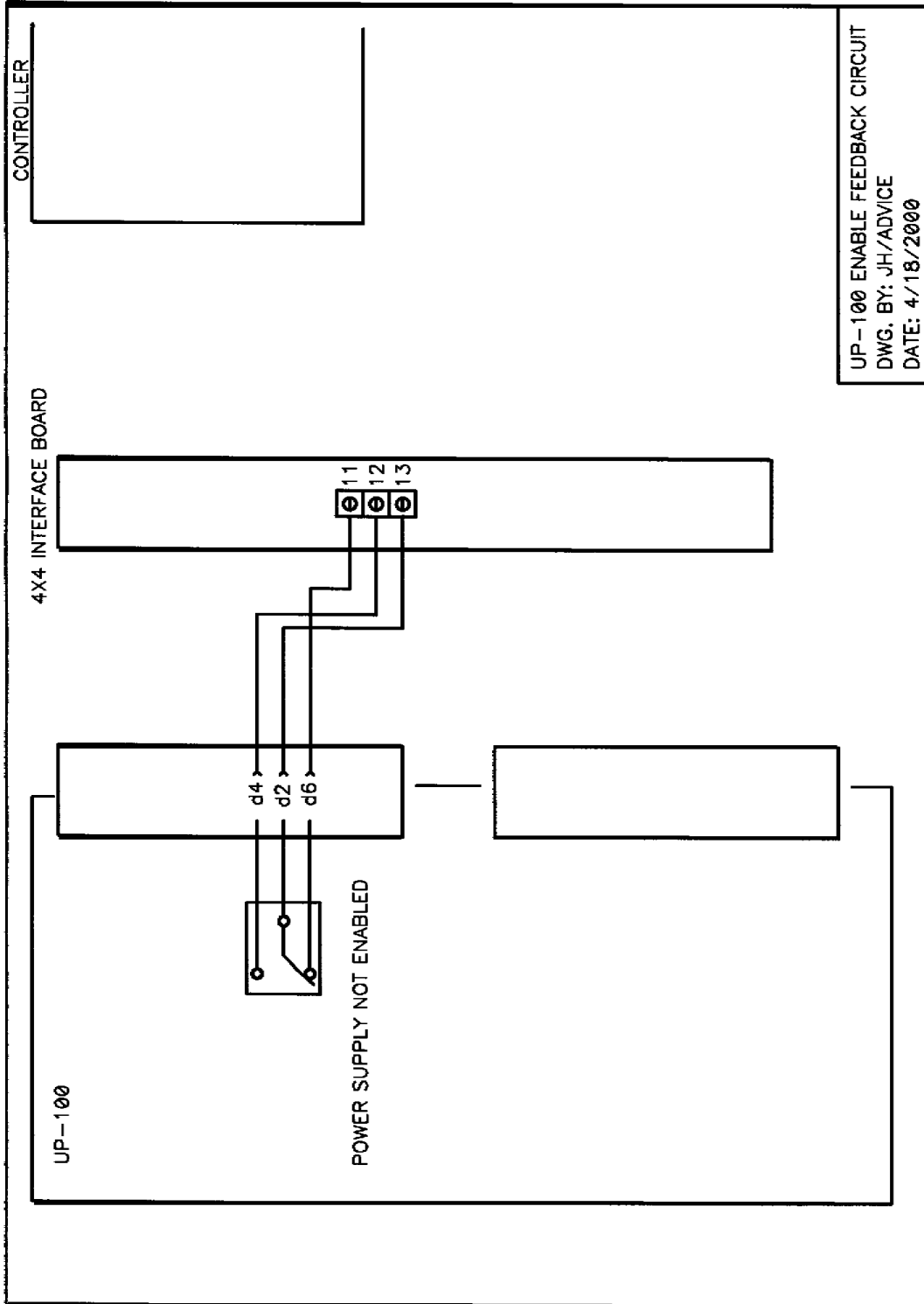

PRELIMINARY

Figure 3: UP-x00 and PS-100 Cascade Interface

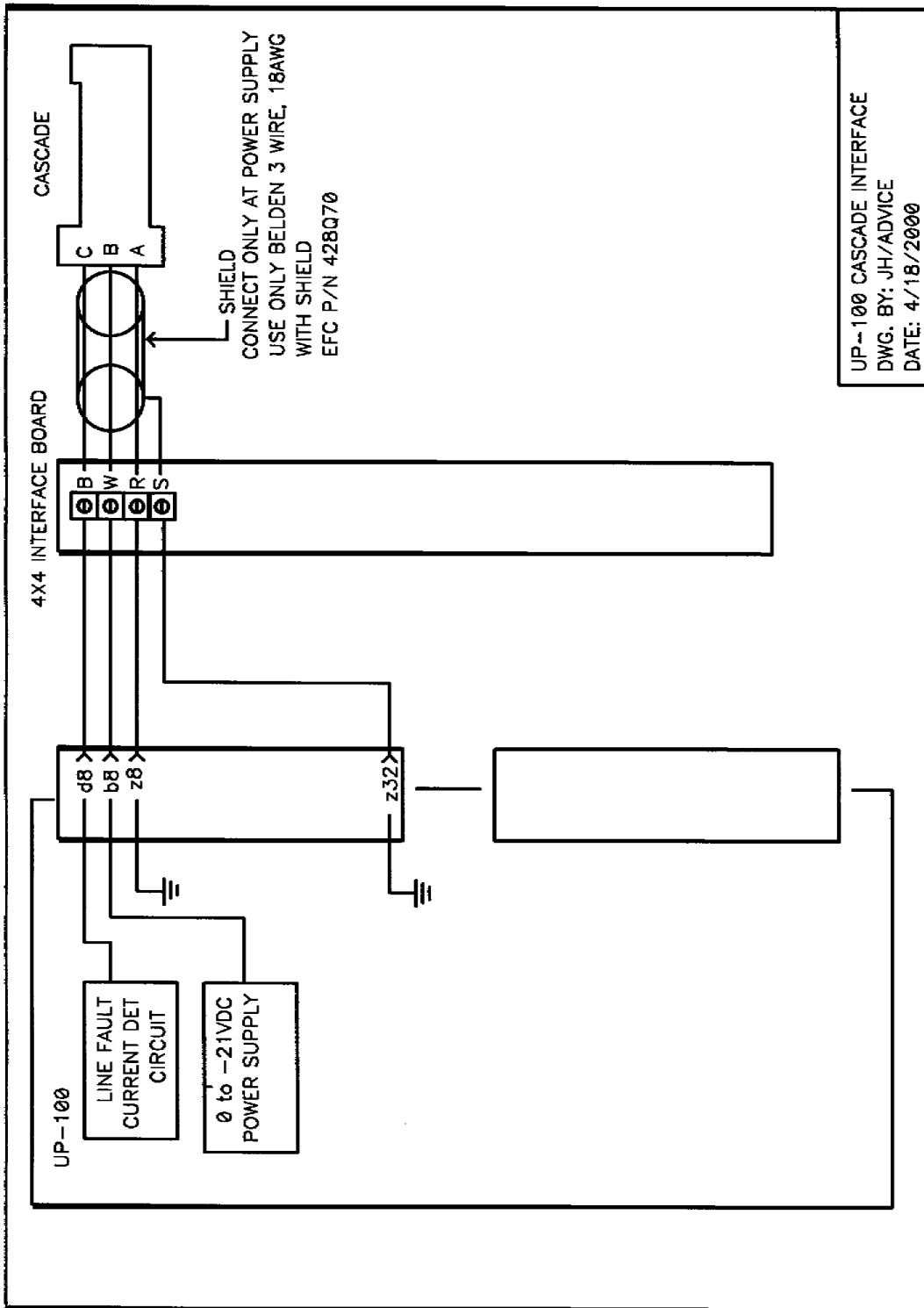

PRELIMINARY

Figure 4: UP-x00 Fault Circuit

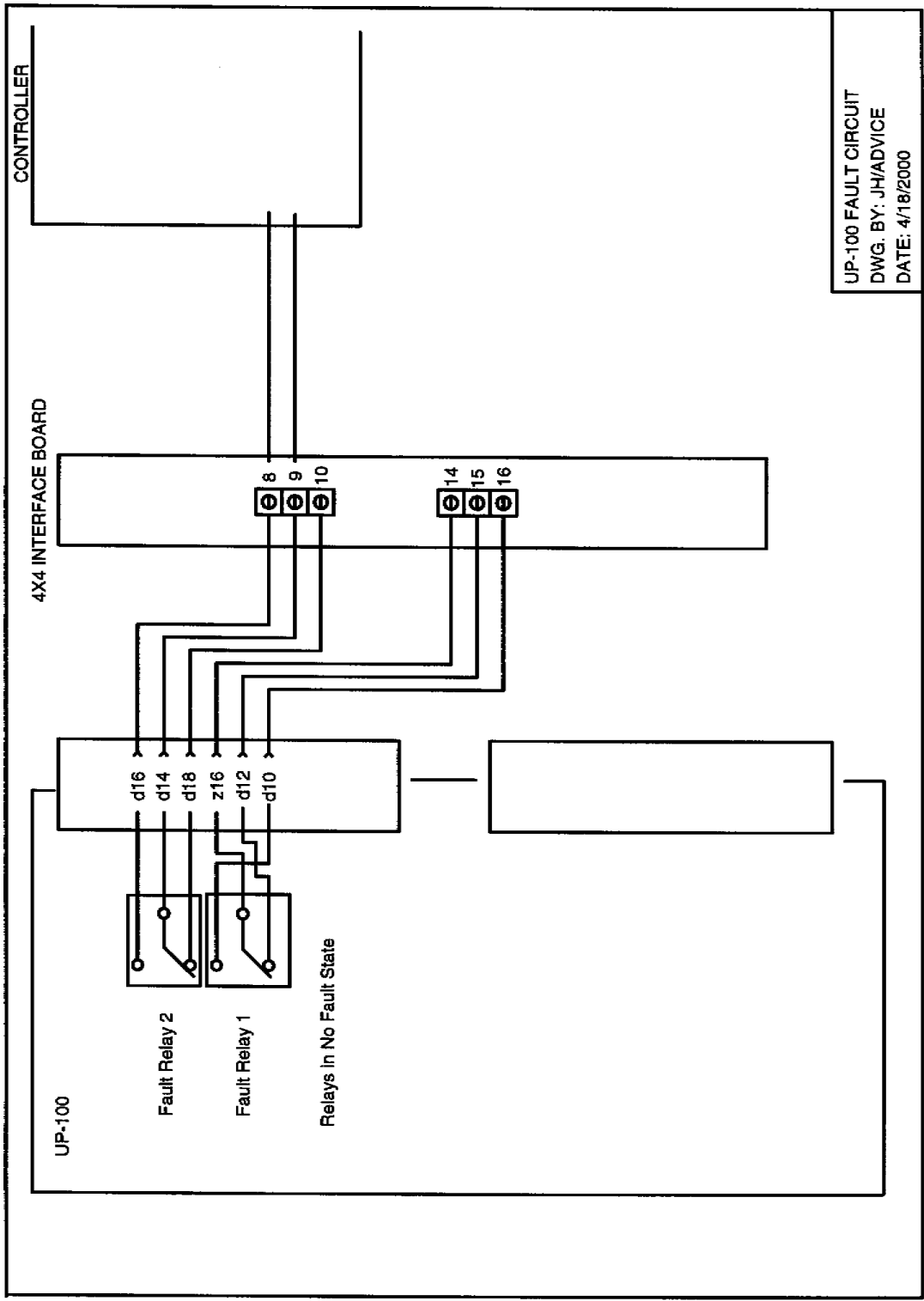

UP-100 FAULT CIRCUIT
 DWG. BY: JH/ADVICE
 DATE: 4/18/2000

PRELIMINARY