

Service and Operations Manual

For the

AFC-400

Quad Air Flow Controller

EFC Systems, Inc.

1325 Post Road

Havre de Grace, MD 21078

Copyright ©2003-2007, all rights reserved. This document is subject to change.

Table of Contents

1	<u>DESCRIPTION</u>	4
1.1	<u>Features</u>	5
2	<u>INSTALLATION</u>	6
3	<u>CONTROLS AND OPERATION</u>	9
3.1	<u>Front Panel Description</u>	9
3.1.1	<u>Airflow controller Digital Flow Meter Windows</u>	9
3.1.2	<u>Status LEDs</u>	9
3.1.3	<u>Power On/Off Switch</u>	9
3.1.4	<u>Local Data Port</u>	9
3.1.5	<u>Up Arrow, Down Arrow, and SET Buttons</u>	9
3.1.6	<u>Front Panel Operation</u>	10
4	<u>CONSOLE USER INTERFACE</u>	11
4.1	<u>Monitor Menu</u>	11
4.1.1	<u>Flow Control Monitor</u>	11
4.2	<u>System Control Menu</u>	12
4.3	<u>Event Log</u>	13
4.4	<u>Dump Configuration</u>	13
4.5	<u>Load Configuration</u>	14
4.6	<u>Save Configuration</u>	15
4.7	<u>System Restart</u>	15
4.8	<u>AirFlow Management</u>	15
4.8.1	<u>Mnemonic</u>	16
4.8.2	<u>Flow Control Settings</u>	16
4.8.2.1	<u>Enable Signal</u>	16
4.8.2.2	<u>Analog Input Interface</u>	17
4.8.2.3	<u>Flow Meter Type</u>	17
4.8.2.4	<u>Operational Mode</u>	18
4.8.2.5	<u>Constant Pressure</u>	19
4.8.2.6	<u>Maximum Pressure</u>	19
4.8.2.7	<u>Pressure Control Tolerance</u>	19
4.8.2.8	<u>Flow Rate Tolerance</u>	20
4.8.2.9	<u>Current Tolerance</u>	20
4.8.2.10	<u>SA Return Tolerance</u>	20
4.8.2.11	<u>PID Control Loop Timeout</u>	21
4.8.2.12	<u>PID Startup Setting</u>	21
4.8.2.13	<u>Proportional Gain</u>	22
4.8.2.14	<u>Integral Gain</u>	22
4.8.2.15	<u>Derivative Gain</u>	22
4.8.2.16	<u>Pilot Air Control</u>	23
4.8.2.17	<u>Pilot Air PV Setting</u>	23

4.8.3	Flow Control Monitor	24
4.8.4	Relay Settings	25
4.8.5	Copy Settings	26
4.8.6	Reset AirFlow	26
4.8.7	Installation Tests	26
4.8.7.1	Set Relay 1	27
4.8.7.2	Clear Relay 1	27
4.8.7.3	Set Relay 2	27
4.8.7.4	Clear Relay 2	27
4.8.7.5	Manual Analog PV Control	27
4.8.7.6	Manual Analog Feedback Control	28
4.8.7.7	Display All Inputs	29
4.8.7.8	Flow Meter Trace	29
4.8.8	System Calibration	30
4.8.9	Learned PV Settings	31
5	TROUBLESHOOTING	32
5.1	Setup Problems	32
5.2	System Problems	33
5.3	Operational Problems	33
6	SPECIFICATIONS	35
6.1	Electrical Specifications	35
6.2	Mechanical Specifications	35
7	CONNECTORS AND PIN-OUTS	36
7.1	Back Plane Connectors	36
7.2	Connector A Pin out	37
7.3	Connector B Pin out	38
7.4	Communications Cable	39
7.5	RS232 Communication Parameters	39
7.6	Save Configuration using HyperTerminal	40
7.7	Recovering Configuration using HyperTerminal	42
7.8	Upgrading Software using HyperTerminal	44

1 Description

The AFC-400 is one of a family of EFC Systems products that form a computer controlled turbine atomizing finishing system. Its purpose is to accurately control and monitor the flow of shaping air through of up to four airflow controllers. The AFC-400 controls pressure (PSI) and monitors pressure and flow rates of up to 999 standard liters per minute (sLPM). Flow rate modulation is accomplished by a closed loop system that controls a proportional valve or pressure transducer. The system employs a Proportional Integral Derivative (PID) feedback loop to maintain tight control of shaping air. Use of closed-loop control allows dynamic compensation for minor system irregularities and improves process repeatability. In addition to providing consistent control over the shaping air, the AFC-400 monitors the system for problems and inconsistencies that would go unnoticed in passive control systems.

The AFC-400 is capable of being operated by a programmable logic controller (PLC), by computer, or via front panel controls. Furthermore, the AFC-400 has remote and local data communication capabilities (RS232 and RS422), allowing for remote management of the system.

The AFC-400 has a convenient three-button front panel interface allowing manual flow rate setting and comparing “raw” and calibrated flow rate and pressure. A front panel data port provides laptop computer “craft interface” to access to flexible setup options, diagnostics, event logs and detailed status reporting features.

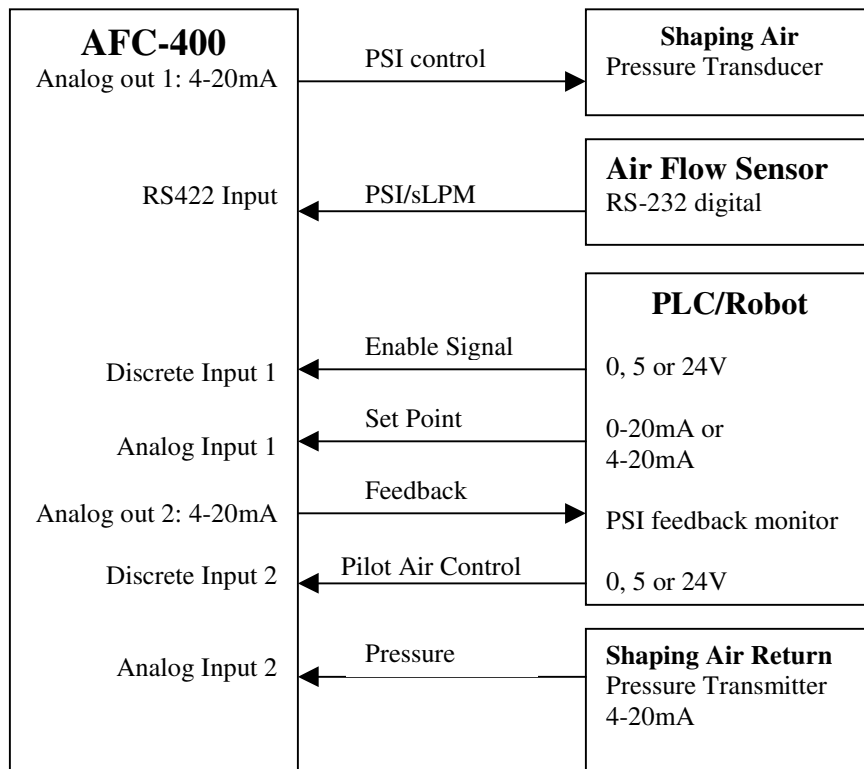

1.1 Features

Fully independent control of four shaping air flows

- Accurate Proportional, Integral, Derivative (PID) closed-loop control
- Supports multiple flow meters:
 - Universal FlowStream
 - Alicat V or M series
- Monitoring Features
 - Maximum pressure limiting
 - Low/High pressure thresholds
 - Low/High flow rate thresholds
 - Low/High shaping air return thresholds
 - Low/High transducer current thresholds
 - Control tolerance threshold

For each AirFlow

- Analog 4-20mA output for proportional valve/transducer control
- Analog 4-20mA output for pressure feedback to controller
- 24V+ supply for external proportional valve
- Analog Input for pressure/flow rate set point from controller
 - 0-20mA
 - 4-20mA
- Shaping Air Enable (on/off) signal input
- Pilot Air Enable (on/off) signal input
- RS-422 input from Universal or Alicat flow meter
- 24V+ power supply for flow meter
- Two multi-purpose SPDT relays
 - Ready signal
 - Fault signal
 - Flow rate reached (latched) signal
 - Flow rate in-tolerance signal
 - Auto-reset for Alicat meters
- Large bright LED digital flow rate/pressure readout

Front panel RS-232 ASCII console management

- Easy to use, menu driven interface
- Time-stamped event log
- Installation Tests
 - Relay on/off tests
 - Manual analog output controls
 - Input displays
 - Flow meter trace
- Detailed PID parameter adjustments
- PID control loop monitor
- Relay function/purpose selection
- Flexible enable signal/mode customization
- Both closed and open loop (transparent) control modes

2 Installation

The AFC-400 fits into a standard 6U – 19” rack that is installed and wired into the painting system before installing the AFC-400. The rack provides a set of connectors (DIN 41612) for the AFC-400 to plug into. Each slot is wired differently; take care to install the AFC-400 into the proper slot. Before installing for the first time, verify that the slot is correctly wired for the AFC-400. Please see Sections 7.1 and 7.3 for the correct pin outs.

The AFC-400 is specifically engineered for the EFC 4X4 rack. This 6-slot rack is designed to contain four UP-200 High-Voltage Power Supplies, one AFC-400 Quad Turbine Speed Controller, and one AFC-400 Quad Air Flow Controller giving a complete Electrostatic/Airflow controller solution for four robots. For more detail, refer to the EFC 4X4 Rack Installation Manual.

When placing the AFC-400 into the rack, be careful that the connectors mate before pushing the unit completely into the slot. When the AFC-400 is completely seated, lock the unit in place with the four quick turn latches. The latches look like normal screws, but require only a ¼ turn to secure the unit in its slot. Install filler panels into unused slots.

After placing the AFC-400 into the rack, use the front panel switch to power-on the unit. The system should flash its indicators and finally result in all four flow meter displays showing 000. If the nothing happens, recheck the power wiring on connector B and verify that the rack itself has power.

Prior to using the system, use the built-in installation tests to verify that the AFC-400 is correctly integrated into the painting system and will be able to reliably control each proportional valve. Before performing the tests, refer to section 3 to gain familiarity with the front panel and console interface features. See section 4.8.7 for more detail on the Installation Tests.

Attach a terminal (or a laptop running HyperTerminal) to the DB-9 Local Data Port on the front panel of the AFC-400. Press the Enter key (or Return) to see the AFC-400 Monitor menu scroll up.

```
AFC-400 Monitor Menu - V2.xx

A - AirFlow A
B - AirFlow B
C - AirFlow C
D - AirFlow D
E - System Control

Select [A..E]:
```

If you don't see anything, verify that the RS232 setup is 9600 bps, 8-bits, 1-stop, No parity. The cable being used should be straight through and flow control settings should be disabled. If using HyperTerminal, verify that Scroll Lock is off. See sections 7.4 and 7.5 for more information on the Local Data Port RS232 connector.

Select item E on the Monitor menu to cause the AFC-400 to display the System Control menu.

```
AFC-400 System Control - Version 2.xx

A - AirFlow A
B - AirFlow B
C - AirFlow C
D - AirFlow D
E - Display Event Log
F - Dump Configuration
G - Load Configuration
H - Save Configuration
I - System Restart
X - Exit

Select [A..I,X]:
```

From the System Control menu, select A-D for the airflow controller to be tested. This menu is detailed in section 4.1. From AirFlow menu, select the option to go to the Installation Tests menu.

```
AirFlow A

A - Mnemonic
B - Control Settings
C - Control Monitor
D - Relay Settings
E - Copy Settings
F - Reset Airflow
G - Installation Tests
H - System Calibration
I - Learned PV Settings
X - Exit

Select [A..I,X]:
```



The Installation Testing menu provides diagnostics to allow quick verification that the AFC-400 is correctly integrated into the rest of the painting system.

```
AirFlow A Installation Testing

A - Set Relay 1
B - Clear Relay 1
C - Set Relay 2
D - Clear Relay 2
E - Manual Analog PV Control
F - Manual Analog Feedback Control
G - Display All Inputs
H - Flow Meter Trace
X - Exit

Select [A..H,X]:
```

First, turn each relay on and off to verify that the AFC-400 can control or signal external equipment. The correct action depends upon the installation. See section 4.8.4 for relay settings.

Test the proportional valve (PV) output to verify that it controls the flow of air. Increasing the output current delivered by the AFC-400 should cause the PV to open and air flow to start. If no air flow is present, check to be sure that pressure is above 14.5 PSI, that the proportional valve has power, and that all hoses are clear. It is also important that the proportional valve is able to close and halt the flow of air.

Test of the proportional feedback current is done similarly to the PV test. The feedback is used to inform the controller of the measured air flow rate. It should be possible to vary the feedback output and observe a flow rate display on the controller or GUI. Use an ammeter if necessary.

The Display All Inputs shows the state of the various input signals to the AFC-400 that is updated each second. Use this display to verify that:

- Input 1 works correctly.
- Input 2 works correctly.
- Voltage or current analog input work as expected.
- Valid data is being received from the flow meter.

AirFlow A Input Display					
AirFlow A					
Input	Input	SetPt	Input	SAR Input	Sensor Reading
1	2	ADC/Units	ADC/Units	sLPM	PSI
High	Low	21d/11.3mA	19f/09.9mA	200	24.6
High	Low	21d/11.3mA	19f/09.9mA	200	24.6
High	Low	21d/11.3mA	19f/09.9mA	200	24.6
High	Low	21d/11.3mA	19f/09.9mA	200	24.6
High	Low	21d/11.3mA	19f/09.9mA	200	24.6
High	Low	21d/11.3mA	19f/09.9mA	200	24.6

If the flow rate/pressure shows blank or appears incorrect, check that the flow meter has power, and that the RS-422 is properly installed. Use the Flow Meter Trace option to view the raw data coming from the flow meter. It may also be necessary to change the setting for the Flow Meter Type. See section 4.8.2.3 for information on setting the Flow Meter Type. The flow meters send readable numbers containing pressure and flow rate data.

3 Controls and Operation

3.1 Front Panel Description

The AFC-400 front panel features a digital flow meter for each of the four shaping air flows labeled A-D. Associated with each airflow is a set of status indicators. A row of three buttons provides for viewing critical operational parameters. A front panel data port provides craft management access to AFC-400 operational status and parameters.

3.1.1 Airflow controller Digital Flow Meter Windows

The front panel displays pressure in pounds per square inch (PSI) absolute. The front panel also displays the flow rate ranging from 000 to 999 standard liters per minute (sLPM). Both calibrated and “raw” readings from the flow meter sensor can be displayed.

3.1.2 Status LEDs

Next to each flow meter window are three indicator LEDs that show status information of the associated airflow.

- **SEL** indicates which airflow is selected for front panel control.
- **R1** indicates that relay 1 is set/engaged.
- **R2** indicates that relay 2 is set/engaged.

The purpose and meaning of the relay activation is configurable to suit the application. See section □ for relay actuation options.

3.1.3 Power On/Off Switch

The main power switch on the front panel controls the incoming AC power. When in the off position, all power to the AFC-400 is turned off. When off, all relays are reset and proportional outputs are set to 4mA.

3.1.4 Local Data Port

This is the front panel interface to a terminal or PC running a terminal program like HyperTerminal. The interface is asynchronous RS232, 9600bps, 8 Bits, No Parity, 1 Stop Bit, Xon/Xoff flow control. For details of its operation, refer to Section 4. This port gives access to AFC-400 information and control via a laptop or other handheld terminal.

3.1.5 Up Arrow, Down Arrow, and SET Buttons

When navigating, the ↑ and ↓ buttons cause the front panel SEL indicator to move up and down along the four airflow controllers. The SET button is pressed to cycle through the various displays for the selected air flow.

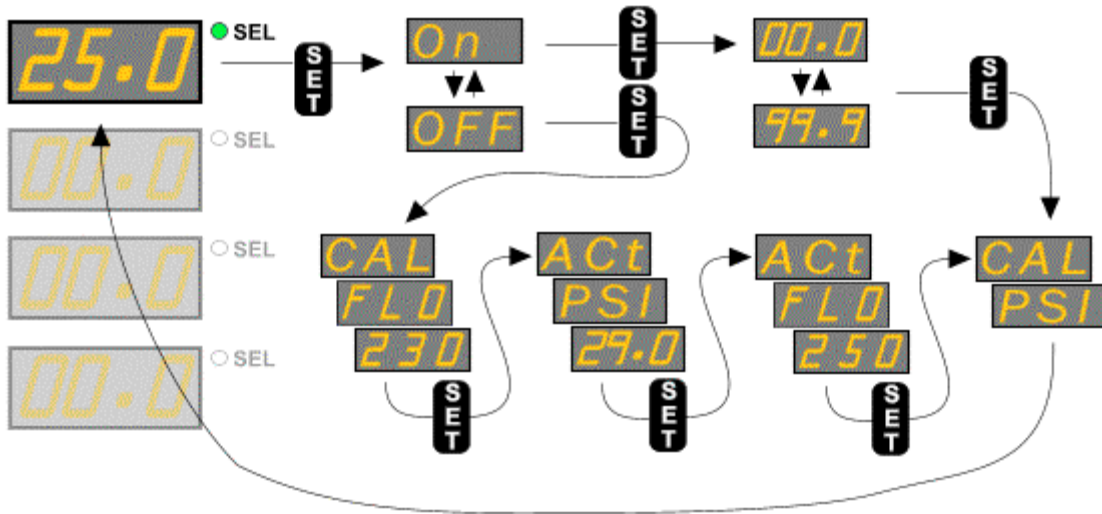

3.1.6 Front Panel Operation

The front panel can be used to control air pressure and view both calibrated and reported values from the air flow sensor.

Start by using \uparrow and \downarrow to select which air flow channel (A-D) to control or monitor. Pressing SET displays the front panel air flow control status. Use the \uparrow and \downarrow to toggle air On or OFF then press SET. If OFF is selected, keep pressing SET to cycle through pressure and flow rate displays. If On is selected, then use the \uparrow and \downarrow to change the air flow pressure set point, and press SET to start the flow of air.

Display Flashes	Value Displayed
<i>CAL FLO</i>	Calibrated flow rate in standard liters/minute (sLPM)
<i>Act PSI</i>	“Raw” pressure reported by the flow sensor (PSI)
<i>Act FLO</i>	“Raw” flow rate reported by the flow sensor (sLPM)
<i>CAL PSI</i>	Calibrated pressure in PSI. This is the normal display.

4 Console User Interface

The AFC-400 console user interface is accessed via the front panel Local Data Port. It is a simple scroll-up menu-driven interface. Attach a console (DTE) to the port and press the Return or Enter key to cause the System Control menu to be displayed. Asynchronous connection setup is 9600/8/None/1. See section 7.5 for details on the Local Data Port RS-232 communications settings.

4.1 Monitor Menu

```
AFC-400 Monitor Menu - V2.xx

A - AirFlow A
B - AirFlow B
C - AirFlow C
D - AirFlow D
E - System Control

Select [A..E]:
```

The Monitor menu is the top-level menu of the console user interface. Select a menu item by pressing the appropriate key.

- | | |
|-------------------|--|
| A. Airflow A | - Monitor status of airflow controller A |
| B. Airflow B | - Monitor status of airflow controller B |
| C. Airflow C | - Monitor status of airflow controller C |
| D. Airflow D | - Monitor status of airflow controller D |
| E. System Control | - Enter the System Control Menu |

4.1.1 Flow Control Monitor

This display is useful for evaluating the effectiveness of the PID Control Loop settings and understanding how the AFC-400 controls the flow of air.

Set Point			Measured			In	Out	Control	
PSI	sLPM	SAR	PSI	sLPM	SAR	mA	mA	Mode	AirFlow A
00.0	000	0.00	---.	---	0.00	00.0	04.0	Reset	
00.0	000	0.00	---.	---	0.00	00.0	04.0	Reset	
00.0	000	0.00	---.	---	0.00	00.0	04.0	Reset	
00.0	000	0.00	---.	---	0.00	00.0	04.0	Reset	
00.0	000	0.00	---.	---	0.00	00.0	04.0	Reset	
00.0	000	0.00	---.	---	0.00	00.0	04.0	Reset	

Columns are:

- **Set Point PSI** – The desired pressure based on the Operational Mode and the Analog Input (4-20mA) current. In Analog or Passive mode, the value is determined by 4-20mA analog input. In Constant Mode, the target pressure is the configured Constant Pressure. The Set Point PSI will be zero while the airflow controller is disabled or analog input is 4mA. In Transparent mode, there is no set point, and this column shows dashes.
- **Set Point sLPM** – The expected flow rate in standard liters per minute. This value is derived from the Set Point PSI and the system calibration. In Transparent mode, there is no set point, and this column shows dashes.
- **Set Point SAR** – This is the expected Shaping Air Return (SAR) pressure in PSI. This value is derived from the SetPoint PSI and the system calibration. In Transparent mode, there is no set point, and this column shows dashes.
- **Measured PSI** – The calibrated and averaged absolute pressure in PSI reported by the flow meter. This column contains dashes when no data is received from the flow meter.
- **Measured sLPM** – The calibrated and averaged flow rate in sLPM reported by the flow meter. This column contains dashes when no data is received from the flow meter.
- **Measured SAR** – This is the Shaping Air Return (SAR) pressure in PSI based on the 4-20mA output of the pressure transmitter. This value will range from 0 to 15 PSI.
- **Input mA** – The milliamps received on the analog command input that is used to determine the set point.
- **Output mA** – The milliamps sent on the 4-20mA analog output that is used to set the pressure transducer or proportional valve that controls the air pressure.
- **Control Mode** – Indicates the state of the control loop. Indications are:
 - **Passive** Operational Mode is Passive.
 - **PID** Proportional Integral Derivative feedback loop.
 - **Reset** The airflow disabled or in a fault condition.
 - **Start** Initial startup interval.
 - **Trans** Operational Mode is Transparent.
 - **Zero** Enabled, with setpoint of 00.0 PSI.

4.2 System Control Menu

```
AFC-400 System Control - Version 2.xx

A - AirFlow A
B - AirFlow B
C - AirFlow C
D - AirFlow D
E - Display Event Log
F - Dump Configuration
G - Load Configuration
H - Save Configuration
I - System Restart
X - Exit

Select [A..I,X]:
```

The System Control menu is the top-level control menu containing options for display and modification of all system parameters. Select a menu item by pressing the appropriate key. Most of the choices lead to other menus, and they are described in the following sections.

- | | |
|-----------------------|---|
| A. Airflow A | - Control parameters for airflow controller 1 |
| B. Airflow B | - Control parameters for airflow controller 2 |
| C. Airflow C | - Control parameters for airflow controller 3 |
| D. Airflow D | - Control parameters for airflow controller 4 |
| E. Display Event Log | - Time stamped log of system events |
| F. Dump Configuration | - Print configuration for capture to a file |
| G. Load Configuration | - Replay captured file to recover a configuration |
| H. Save Configuration | - Persist configuration into flash memory |
| I. System Restart | - Restarts software and enters boot monitor program |

4.3 Event Log

The Event Log is option E from the System Control menu. The log contains a record of system events. Each log entry consists of a timestamp and a textual message describing the event. The AFC-400 does not contain a real-time clock, so the timestamp is relative to the time the AFC-400 was turned on. The log is not persisted between restarts of the system.

```
0.00:00:00.000 Warm Restart
0.00:00:00.000 Begin Operation
0.00:02:09.091 AirFlow A Control Prevented
0.00:02:16.420 AirFlow A Control Allowed

Log is On, Off = [Space Bar] Exit = [X]

0.00:18:03.915 Airflow D Local Rate set to 350 sLPM
```

If events are occurring too rapidly, the spacebar can be used to toggle the log updating on and off. Press [X] or [Escape] to return to the System Control menu.

4.4 Dump Configuration

The Dump Configuration is used to make a record of AFC-400 configuration. The record is in text format, so it can be saved to a PC disk drive and later viewed (and even modified) using a text editor. The configuration record can be recovered by using the Load Configuration feature. Selecting the Dump Configuration option causes the following prompt to be displayed:

```
Prepare PC/HyperTerminal to receive configuration file.  
Press any key to continue:
```

At this point, prepare the terminal program to receive a text file then press Enter to cause the AFC-400 to start transmitting its configuration. The output will look something like the following:

```
<  
0.OpMode=Transparent  
0.AnalogInput=4-20mA  
0.EnableSignal=Input 1 High  
0.Meter=Universal 2400  
0.Const=20.0  
.  
.  
.  
3.SetPt.10.MeterSLPM=000  
3.SetPt.10.SARADC=000  
3.SetPt.10.SARPSI=0.00  
>
```

When the output has completed, close the captured text file. This file can be viewed and edited using any standard text editor (e.g. Notepad.exe). When editing, it is advantageous, though not necessary, to retain the beginning and ending < > characters, as these identify the start and end of the configuration data.

4.5 Load Configuration

The Load Configuration is used to recover a system configuration that was earlier saved using the Dump Configuration facility. Selecting the Load Configuration option causes the following prompt to be displayed:

```
Select [A..I,X]: G  
  
Ready to receive configuration file
```

At this point, cause the terminal program to send the text file containing the AFC-400 configuration data. It will be necessary to control the flow of data to the AFC-400. Set flow control to xon/xoff. During the load, all is well if a \$ is printed before the start of each line echoed by the AFC-400. An echoed ? or ! means that the line was misunderstood or there was some transmission error.

```
$0.OpMode=Transparent
$0.AnalogInput=4-20mA
$0.EnableSignal=Input 1 High
$0.Meter=Universal 2400
.
.
.
$3.SetPt.10.MeterPSI=00.0
$3.SetPt.10.MeterSLPM=000
$3.SetPt.10.SARADC=000
$3.SetPt.10.SARPSI=0.00
$
```

When the file has been fully received, the System Control menu will be redisplayed. Examine the Event Log to see what configuration options were changed as a result of the load.

4.6 Save Configuration

The Save Configuration feature is used to force the immediate saving of the current configuration settings into permanent storage in flash memory. This feature is present for those who are in a hurry, as all changes made to the configuration are automatically saved within 30 seconds.

4.7 System Restart

Choosing the System Restart option from the top-level menu causes the AFC-400 to perform a warm restart of the system. Console control will fall back to the Boot Monitor software after the restart. The Boot Monitor interface contains some hardware self-diagnostic tests and allows for downloading/upgrading of the AFC-400 operational software.

4.8 AirFlow Management

From the System Control menu, select options A-D to view and modify configuration settings and view status and diagnostics for each individual airflow controller.

```
AirFlow A

A - Mnemonic
B - Control Settings
C - Control Monitor
D - Relay Settings
E - Copy Settings
F - Reset Airflow
G - Installation Tests
H - System Calibration
I - Learned PV Settings
X - Exit

Select [A..I,X]:
```

There are effectively four independent air flow controllers in the system, each with individually adjustable configuration parameters. Most of the selections on this menu lead to other menus.

4.8.1 Mnemonic

This option allows changing the designation of each air flow controller.

```
AirFlow A Mnemonic
```

```
The mnemonic is a very short (up to 3 characters) name
used to identify the AirFlow in the system.
```

```
Enter new mnemonic for this AirFlow:
A
```

The mnemonic can be up to 3 printable characters. The default value is A-D corresponding to airflow controller 1-4.

4.8.2 Flow Control Settings

```
AirFlow A Settings

A - Enable Signal           Input 1 High
B - Analog Input Interface  4-20mA
C - Flow Meter Type        Universal 2400
D - Operational Mode        Constant
E - Constant Pressure      22.0 PSI
F - Maximum Pressure        90.0 PSI
G - Pressure Control Tolerance +/- 01.5 PSI
H - Flow Rate Tolerance     +/- 000 sLPM
I - Current Tolerance       +/- 00.0 mA
J - SA Return Tolerance     +/- 0.10 PSI
K - PID Control Timeout     4 s
L - PID Startup Delay       1000 ms
M - PID Startup Setting     20%
N - Proportional Gain       100
O - Integral Gain           50
P - Derivative Gain         0
Q - Pilot Air Control        Input 2 High
R - Pilot Air Setting        00.0 mA
X - Exit

Select [A..R,X]:
```

4.8.2.1 Enable Signal

This parameter specifies how the controller tells the AFC-400 when to start monitoring or controlling airflow. When airflow is disabled, the setpoint pressure is 0.0 PSI, the set point flow rate is 000 sLPM and any control system fault conditions are reset. When enabled, the system establishes the desired pressure, monitors the flow rate, and evaluates the performance of the PID control loop. When set to *Input 1 Ignored*, the PID control loop is disabled by setting the setpoint flow rate to 000 sLPM.

```
Enable Signal controls how the AFC-400 will determine when to
begin air flow monitoring or controlling activities.
```

```
Input 1 Low      = Enabled when input signal is low
Input 1 High     = Enabled when input signal is high
Input 1 Ignored  = Enabled whenever air flow is requested
Always          = Enabled when power is on
```

```
Enable Mode is currently: Input 1 High
```

```
Select Enable Signal Option
```

```
A - Input 1 Low
B - Input 1 High
C - Input 1 Ignored
```

```
Select [A..C]:
```

To change this parameter, press the key [A, B, C] corresponding to the correct selection for the control system. Press Enter or Escape to leave the Enable Signal setting intact. The default setting is ***Input 1 High***.

4.8.2.2 Analog Input Interface

When Operational Mode is set to Analog, this setting specifies how the airflow controller's desired flow rate is determined. There are three methods supported by the AFC-400:

```
Analog Input Interface allows tailoring the AFC-400 to
The following methods of analog flow rate selection.
0-20mA - Linear min = 0mA, max = 20mA
4-20mA - Linear min = 4mA, max = 20mA
```

```
Analog Input is: 4-20mA
```

```
Select Analog Input Interface
```

```
A - 0-20mA
B - 4-20mA
```

```
Select [A..B]:
```

Each method allows an external controller to continuously vary the setpoint pressure and flow rate by varying current. Press Enter or Escape to leave the selection unchanged. The lowest current will set the setpoint pressure to atmospheric (0 or 14.3 PSI absolute), and the 20 milliAmperes will set the pressure and flow rate to maximum. The default setting is ***4-20mA Current***.

4.8.2.3 Flow Meter Type

Specifies the type of air flow meter that is employed in the painting system.

```
Select which type of flow meter is being used.
```

```
Meter currently selected is: Universal FlowStream
```

```
Select Flow Meter
```

```
A - Universal FlowStream
B - Alicat V-series
C - Alicat M-series
D - Universal 2400
```

```
Select [A..C]:
```

To change this parameter, press the letter corresponding to the type of flow meter being used. Press Enter or Escape to leave the setting intact. The default Flow Meter Type is *Universal FlowStream*.

4.8.2.4 Operational Mode

This parameter specifies how the setpoints will be selected and whether the AFC-400 will provide closed-loop pressure control, or will work open-loop. In all modes, the AFC-400 monitors the actual pressure and flow rate and reports pressure to the controller via analog 4-20mA feedback outputs. The AFC-400 can be configured to signal a fault condition if the measured flow rate fails to remain within tolerance.

In Passive Mode, pressure and flow rate are controlled externally and the AFC-400 monitors them to verify they remain within thresholds. The AFC transparently passes through the analog input current – it does not control the pressure, but it is aware of the set point pressure and flow rate. Use Transparent Mode if no monitoring is desired.

In Transparent Mode, the AFC-400 allows the system controller to directly determine the air pressure by passing through the analog input to the proportional valve. The AFC-400 acts as an adapter by mapping the analog input from the controller (0-20mA or 4-20mA) into 4-20mA current output to the proportional valve. In this mode, the AFC-400 provides no threshold monitoring. Use Passive Mode, to employ transparent control but retain the fault monitoring features.

In Constant Mode, the AFC-400 actively provides closed-loop control of the shaping air pressure. When enabled, the AFC-400 will quickly establish and maintain the configured Constant Pressure. In Constant Mode, AFC-400 can set a fault relay if it cannot maintain both pressure and flow rate within thresholds.

In Analog Mode, the AFC-400 actively controls the air pressure. When enabled, the AFC-400 will establish the set point pressure based on the analog input current. This allows the controller to vary the shaping air dynamically during the painting process. In Analog Mode, AFC-400 can set a fault relay if it cannot maintain both pressure and flow rate within thresholds.

```
Operational Mode allows tailoring the AFC-400 to various
control mechanisms and protocols. In all modes the system
will monitor and react to any detected system fault
conditions.
Analog      - Closed-loop pressure selected by analog input
Transparent - Open-loop control via analog input
Constant    - Closed-loop constant pressure when enabled
Passive     - Monitor and report pressure and flow rate
```

```
Operational Mode is currently: Passive
```

```
Select Operational Mode
```

```
A - Analog
B - Transparent
C - Constant
D - Passive
```

```
Select [A..D]:
```

Select the Operational Mode by pressing the corresponding letter. Press Enter or Escape to leave the selection unchanged. The default Operational Mode is *Passive*.

4.8.2.5 Constant Pressure

This parameter specifies the setpoint pressure when the airflow controller is enabled in Constant operational mode.

```
The Constant Pressure specifies the set point pressure when
the Operational Mode is set to Constant. The Constant
Operation Mode works as an on/off control. When operating
in Constant mode, enabling the AirFlow will cause the
the pressure to be set to the Constant Pressure value.
```

```
Enter new Setting for Constant Pressure (PSI):
14.0
```

To enter a new speed value in sLPM, backspace over the number and type in a new value. Pressing Enter or Escape leaves the Constant Flow Rate unchanged. The default value for Constant Pressure is 14.0 PSI. Note: Use the Pilot Air setting (4.8.2.16) to provide a trickle of air flow while the system is idle.

4.8.2.6 Maximum Pressure

This parameter specifies the highest selectable air pressure. This will be the highest pressure permitted by the control system. When Operational Mode is set to Analog, maximum inputs of 20 mA will set the pressure to the Maximum Pressure.

```
The Maximum Pressure establishes a ceiling for the pressure.
This will be the set point pressure at 20.0mA of input.
The system will limit the pressure to below this value.
Should the pressure exceed this value a fault signal
will be raised.
```

```
Enter new Setting for Maximum Pressure (PSI):
90.0
```

To change this parameter, backspace over the number and type in a new value. Pressing Enter or Escape leaves the setting unchanged. The default Maximum Pressure is 90 PSI.

4.8.2.7 Pressure Control Tolerance

This parameter specifies the allowed range of pressure that the system is allowed to provide. If the AFC-400 cannot reliably maintain air pressure within this range, then it will indicate a fault condition. Failure to keep the pressure within tolerance is indicative of a problem somewhere in the air control system – possible causes could be a leak, a clog, or a failed sensor. Please see the troubleshooting section for suggestions on how to locate the cause of the fault.

```
The Pressure Control Tolerance specifies how accurate the
control loop must be when establishing pressure. Correct
selection of the range should take into account accuracy of the
sensors as well as the linearity of the air flow control
valves. Too tight of a tolerance may result in the control
system hunting above and below the desired set point.
```

```
Enter new Setting for Control Tolerance (+/- PSI):
```

To change the Pressure Control Tolerance, backspace over the number and type in a new value. Pressing Enter or Escape leaves the value unchanged. The default Pressure Control Tolerance is +/- 5 PSI, but can be tighter in normal use.

4.8.2.8 Flow Rate Tolerance

This parameter specifies the allowed flow rate tolerance. If the AFC-400 cannot reliably maintain air flow rate within this range, then it will indicate a fault condition. Failure to keep the flow rate within tolerance is indicative of a problem somewhere in the painting system. Please see the troubleshooting section for suggestions on how to locate the cause of the fault.

```
Flow Rate Tolerance is used to detect impending air flow problems
due to clogging or leakage. The AFC-400 constantly monitors air
flow rate while enabled. The AFC-400 will signal a fault condition
if the flow rate exceeds or falls below this threshold. The default
setting of 00.0 sLPM disables flow rate thresholding.
```

```
Enter new value for Flow Rate Tolerance (+/- sLPM):
000
```

To change the Flow Rate Tolerance, backspace over the number and type in a new value. Pressing Enter or Escape leaves the value unchanged. The default Flow Rate Tolerance is +/- 0 sLPM – which disables the flow rate tolerance checking.

4.8.2.9 Current Tolerance

This parameter specifies the allowed range of current (mA) that can be applied to the pressure control transducer or proportional valve. This threshold is useful when working in closed loop modes (Analog or Constant). If the AFC-400 has to apply too much or too little current to establish the set point pressure, then something may be wrong with the proportion air valve or its inlet air pressure. Please see the troubleshooting section for suggestions on how to locate the cause of the fault.

```
Current Tolerance is used to detect problems with the air pressure
control valve when operating in closed-loop mode. If the AFC-400
has to apply excessive current to maintain pressure, then the
proportional pressure valve may have a problem or perhaps the source
air pressure has changed.
```

```
Enter new value for Current Tolerance (+/- mA):
00.0
```

To change the Current Tolerance, backspace over the number and type in a new value. Pressing Enter or Escape leaves the value unchanged. The default Current Tolerance is +/- 0 mA – which disables the output current tolerance checking.

4.8.2.10 SA Return Tolerance

This parameter establishes the range that the shaping air return (SAR) pressure is allowed to deviate from the expected value. The shaping air measures the pressure inside the manifold in the PEA, and is a sensitive instrument for detecting nearly any variance in the shaping air.

Shaping Air Return Tolerance specifies the acceptable error measured by the SAR pressure sensor. It is a fault condition if the difference between the expected and measured pressure exceeds the SAR Tolerance. A zero value disables checking of the shaping air return pressure.

Enter new value for Shaping Air Return Tolerance (+/- PSI):
0.50

To change the SA Return Tolerance, backspace over the number and type in a new value. Pressing Enter or Escape leaves the value unchanged. The default SA Return Tolerance is +/- 0 PSI – which disables the shaping air pressure checking.

4.8.2.11 PID Control Loop Timeout

This parameter specifies the maximum time in seconds that the control system is permitted to be out of tolerance. The timeout interval starts when the airflow controller is enabled and the setpoint pressure is above 18.0 PSI and the setpoint flow rate is above 0 sLPM. The AFC-400 will signal a fault condition if it cannot achieve and maintain the desired flow rate before the Control Loop Timeout interval. The inability of the AFC-400 to maintain the desired flow rate is indicative of a problem somewhere in the system. See the section on fault determination and resolution for information on how to locate the root cause of the problem.

The PID Control Timeout specifies a time limit for the control loop to establish the correct set point. If the PID control loop is unable to achieve the target flow pressure, then the control system is likely impaired and should be inspected for problems.

Enter new value for Control Loop Fault Timeout (seconds):
10

To change this parameter, backspace over the number and type in a new value. Pressing Enter or Escape leaves the setting unchanged. The default value is 10 seconds, but this time should be reduced to 5 seconds after the system is up and running.

4.8.2.12 PID Startup Setting

This parameter establishes a fixed proportional valve setting to be applied when the airflow controller is initially enabled. This setting is applied for the PID Startup Interval before switching over to the PID feedback loop control. The purpose of the Startup Setting is to get the setpoint pressure established quickly while the initial pressure and flow rate readings are being measured by the flow meters. A carefully tuned Startup Setting and Startup Interval can place the flow rate at or near the set point more quickly than PID alone.

Enter new value for the PID Startup Setting (0 to 100%):
20

To change this parameter, backspace over the number and type in a new value. Pressing Enter or Escape leaves the setting unchanged. The default PID Startup Setting is 50%.

4.8.2.13 Proportional Gain

This parameter determines how strongly the PID feedback control loop will react when correcting for instantaneous flow rate errors. Correction will be proportional to the difference between the measured flow rate and the desired flow rate. Setting this gain value too high can result in over-correction, leading to oscillation around the target rate. Too low a setting will result in weak response and slow flow rate adjustment

```
The Proportional Gain establishes how aggressively the
control loop will react to the difference between the
currently measured and the target set point. Larger values
cause faster system response, but too large a value may
result in excessive overshoot or oscillation.
```

```
Enter new value for Proportional Gain:
100
```

To change this parameter, backspace over the number and type in a new value. Pressing Enter or Escape leaves the setting unchanged. The default Proportional Gain is 100

4.8.2.14 Integral Gain

This parameter is similar to proportional gain, but weights the control system's response to the sum of long-term errors. The Proportional Gain gets the system close, and the Integral Gain provides the ultimate convergence to the set point pressure.

```
The Integral Gain helps to fine adjust the system to
converge to a stable pressure. A small value will cause
the system to take a long time to reach the set point.
Like other parameters, too large a value will cause
oscillations and slow convergence.
```

```
Enter new value for Integral Gain:
100
```

The AFC-400 is constantly learning what proportional valve current establishes what pressure and flow rate, so strong PID control is not required for fast response. These gain values will be used to fine adjustments, and it is recommended to set these gain values conservatively low. To change this parameter, backspace over the number and type in a new value. Pressing Enter or Escape leaves the setting unchanged. The default value for the Integral Gain is 50.

4.8.2.15 Derivative Gain

This parameter affects how much weighting the control system will give to acceleration when computing flow rate adjustments. Increasing Derivative Gain adds damping to the system. Correct settings for this value will allow larger Proportional and Integral gain values to be used, allowing stronger speed control and quicker system response.

```
The Derivative Gain helps to compensate for latency in the
control system. It may not always be necessary, but can be
useful in final tuning to reduce overshoot and minor
oscillations produced by optimal Integral and Proportional
Gain settings.
```

```
Enter new value for Derivative Gain:
0
```

To change this parameter, backspace over the number and type in a new value. Pressing Enter or Escape leaves the setting unchanged. The default value for the Derivative Gain is 0.

4.8.2.16 Pilot Air Control

This parameter specifies how the controller tells the AFC-400 when to enable pilot air flow. The pilot or idle air can be used to help keep the system clean between jobs, or to start air flowing before the start of a job. The correct amount of pilot air flow will have to be determined by experimentation, see the next section for how to set the flow rate of the pilot air.

```
In situations where it is critical to rapidly establish working
air pressure, it can be advantageous to maintain some flow when
the system is idle. The Pilot Air Control determines how the
controller will enable and disable the pilot air flow.
  Input 2 Low  = Pilot air on when input 2 is low
  Input 2 High = Pilot air on when input 2 is high
  Enabled     = Pilot always on
  Disabled    = Pilot always off
```

```
Pilot Air Control is currently set as: Input 2 High
```

```
Select Pilot Air Flow Control Option
```

```
A - Input 2 Low
B - Input 2 High
C - Enabled
D - Disabled
```

```
Select [A..D]:
```

To change this parameter, press the key [A, B, C, D] corresponding to the correct selection. Press Enter or Escape to leave the setting intact. The default setting is ***Input 2 High***.

4.8.2.17 Pilot Air PV Setting

This parameter is used to keep the shaping air proportional valve open and air flowing even when the shaping air flow is disabled. The pilot air is used to generate a trickle of air flow when the system is otherwise disabled to help keep the air nozzles clear between painting operations. Additionally, the pilot air can be used to permit faster startup of the airflow. Having non-zero starting flow rate may be advantageous in cases where it is important to have very quick establishment of the closed loop air flow.

```
In situations where it is critical to rapidly establish working
air pressure, it can be advantageous to maintain some flow of
air when the system is idle. The ideal pilot air flow can be
determined by experimentation. Set to 0.0 mA to disable the
pilot air.
```

```
Enter new value for the Pilot Air PV Setting (mA):
00.0
```

The input value is the current (range between 4 and 20mA) that is sent to the proportional air valve or pressure transducer. Adjust by experimentation until the desired idle air flow rate is achieved. To change this parameter, backspace over the number and type in a new

value. Pressing Enter or Escape leaves the setting unchanged. The default value is 0.0, which completely turns off the flow of air.

4.8.3 Flow Control Monitor

This display is useful for evaluating the effectiveness of the PID Control Loop settings and understanding how the AFC-400 controls the flow of air.

Set Point			Measured			In	Out	Control	
PSI	sLPM	SAR	PSI	sLPM	SAR	mA	mA	Mode	AirFlow A
00.0	000	0.00	---.-	---	0.00	00.0	04.0	Reset	
00.0	000	0.00	---.-	---	0.00	00.0	04.0	Reset	
00.0	000	0.00	---.-	---	0.00	00.0	04.0	Reset	
22.0	154	1.50	---.-	---	0.00	00.0	05.7	Start	Fault
22.0	154	1.50	---.-	---	0.00	00.0	05.7	Start	Fault
22.0	154	1.50	---.-	---	0.00	00.0	05.7	Start	Fault
22.0	154	1.50	---.-	---	0.00	00.0	05.7	Start	Fault
22.0	154	1.50	---.-	---	0.00	00.0	07.3	PID: +dc +357 +0	Fault
22.0	154	1.50	---.-	---	0.00	00.0	08.2	PID: +dc +420 +0	Fault

Columns are:

- **Set Point PSI** – The desired pressure based on the Operational Mode and the Analog Input (4-20mA) current. In Analog or Passive mode, the value is determined by 4-20mA analog input. In Constant Mode, the target pressure is the configured Constant Pressure. The Set Point PSI will be zero while the airflow controller is disabled or analog input is 4mA. In Transparent mode, there is no set point, and this column shows dashes.
- **Set Point sLPM** – The expected flow rate in standard liters per minute. This value is derived from the Set Point PSI and the system calibration. In Transparent mode, there is no set point, and this column shows dashes.
- **Set Point SAR** – This is the expected Shaping Air Return (SAR) pressure in PSI. This value is derived from the SetPoint PSI and the system calibration. In Transparent mode, there is no set point, and this column shows dashes.
- **Measured PSI** – The calibrated and averaged absolute pressure in PSI reported by the flow meter. This column contains dashes when no data is received from the flow meter (as in the above example).
- **Measured sLPM** – The calibrated and averaged flow rate in sLPM reported by the flow meter. This column contains dashes when no data is received from the flow meter.
- **Measured SAR** – This is the Shaping Air Return (SAR) pressure in PSI based on the 4-20mA output of the pressure transmitter. This value will range from 0 to 15 PSI.
- **Input mA** – The milliamps received on the analog command input that is used to determine the set point.

- **Output mA** – The milliamps sent on the 4-20mA analog output that is used to set the pressure transducer or proportional valve that controls the air pressure.
- **Control Mode** – Indicates the state of the control loop. Indications are:
 - **Passive** Operational Mode is Passive.
 - **PID** Proportional Integral Derivative feedback loop.
 - **Reset** The airflow disabled or in a fault condition.
 - **Start** Initial startup interval.
 - **Trans** Operational Mode is Transparent.
 - **Zero** Enabled, with setpoint of 00.0 PSI.

Out to the right of each line is a field that can contain special status of the controller.

4.8.4 Relay Settings

The AFC-400 provides flexible relay options to optimize integration with the control system. There are two Single-Pole Dual Throw (SPDT) relays for each of the four shaping air controllers. When the system is off, all relays are in their reset position. When reset, the Common and Normally Closed (NC) are connected. When a relay is set, the Common and Normally Open (NO) are connected.

```

AirFlow A Relays

A - Relay 1                               Set within Tolerance
B - Relay 2                               Set on Fault
X - Exit

Select [A..B,X]:
```

Each relay is independently configurable, and the same menu of options is presented for both relays.

```

AirFlow A Relay 1 Mode is: Set within Tolerance

Select Relay Operation

A - Unused
B - Set on Fault
C - Set while Ready
D - Set within Tolerance
E - Set when SetPoint Reached
F - Set for Meter Reset

Select [A..F]:
```

- A. **Unused** – The relay will remain in its reset position.
- B. **Set on Fault** – The relay is set when a fault condition is detected. The relay will be reset when the airflow controller is disabled.
- C. **Set while Ready** – The relay is set when the system is powered on and is not in a fault condition.
- D. **Set within Tolerance** – The relay is set while the airflow controller is enabled and the pressure is within tolerance. The relay is otherwise reset.

- E. **Set when SetPoint Reached** – The relay is set after the setpoint pressure is first established, and remains set until the airflow controller is disabled.
- F. **Set for Meter Reset** – The relay is momentarily set and then reset each time the airflow controller is disabled in order to reset and re-zero the flow meter.

Select the Relay Mode by pressing the corresponding letter. Press Enter or Escape to leave the current selection unchanged. The default mode for Relay 1 is **Set within Tolerance** The default mode for Relay 2 is **Set on Fault**.

4.8.5 Copy Settings

The Copy Settings facility is used to copy the configuration setup of this air flow controller to another airflow controller in the AFC-400. Once the ideal configuration settings are determined for one controller, this feature can be used to quickly establish the same settings on the other controllers.

```
Copy to which AirFlow?
A - AirFlow B
B - AirFlow C
C - AirFlow D
D - All
X - Exit

Select [A..D,X]:
```

Select the AirFlow controller to receive the configuration and confirm the operation. Choosing option D copies the settings to the other 3 air flow controllers.

4.8.6 Reset AirFlow

This feature is used during installation and testing to clear air flow control fault conditions arising from faulty configuration or other temporary problems arising while testing the system.

```
Confirm Reset?
A - Yes
B - No

Select [A..B]:
```

Select A to reset the airflow and all fault indications.

4.8.7 Installation Tests

This menu contains options that are useful during installation for testing the AFC-400 interfaces with the rest of the painting system. See section 2 for details on how these tests can be used during installation.

```
AirFlow A Installation Testing

A - Set Relay 1
B - Clear Relay 1
C - Set Relay 2
D - Clear Relay 2
E - Manual Analog PV Control
F - Manual Analog Feedback Control
G - Display All Inputs
H - Flow Meter Trace
X - Exit

Select [A..H,X]:
```

4.8.7.1 Set Relay 1

Sets, or engages Relay 1 (R1). By default, this relay is used to indicate when the flow rate is within set tolerance, but may be used for other purposes. Setting the relay will light the associated front panel R1 indicator. When setting and clearing the Relay, it should also be possible to hear the relay flip from on position to the other.

4.8.7.2 Clear Relay 1

Resets Relay 1 (R1) and turns off the associated R1 indicator on the front panel.

4.8.7.3 Set Relay 2

Sets, or engages, Relay 2 (R2). By default, this relay is used to indicate a Fault condition. However, the relay may be used for other purposes. See section 4.8.4 for relay options. Setting the relay will light the associated front panel R2 indicator. When setting and clearing the Relay, it should also be possible to hear the relay switch.

4.8.7.4 Clear Relay 2

Resets Relay 2 (R2) and turns off the associated R2 indicator on the front panel.

4.8.7.5 Manual Analog PV Control

This feature allows manual adjustment of the proportional valve (PV) or pressure transducer control current. Use of this test can verify that the pressure transducer is working, and that the AFC-400 has the capability of controlling it.

After choosing this option, the following short menu is presented to remind the operator that active air flow control will be suspended while manually controlling the proportional valve setting.

```
Safe to suspend air flow control?

A - Yes
B - No
```

Select [A..B]:

Selecting anything but [A] will return to the Integration Test menu.

```
Airflow A Manual PV Control

Use keyboard to adjust output current between 4 and 20 mA
[-][+] to decrement or increment by 1mA
[X][Esc] to exit

PV output = 4 mA
```

The [+] and [-] keyboard keys are used to increment or decrement the output current at 1 mA steps. Return to the Installation Testing menu by pressing X or Escape.

4.8.7.6 Manual Analog Feedback Control

This feature allows manual adjustment of the analog feedback control current. This current is used to inform the system controller (PLC) of the measured flow rate. Use of this test can verify that the feedback signal is working and correctly calibrated. Feedback is intended to be 20mA at the configured Maximum Pressure. See section 4.8.2.6 on how to set the Maximum Pressure.

```
Airflow A Manual Feedback Control

Use keyboard to adjust output current between 4 and 20 mA
[-][+] to decrement or increment by 1mA
[X][Esc] to exit

Feedback output = 4 mA
```

The [+] and [-] keyboard keys are used to increment or decrement the output current at 1 mA steps. Return to the Installation Test menu by pressing X or Escape.

4.8.7.7 Display All Inputs

Selecting this option starts a display that automatically displays updated values for the various input control signals associated with the airflow controller under test.

AirFlow A					
Input 1	Input 2	SetPt Input ADC/Units	SAR Input ADC/Units	Sensor sLPM	Reading PSI
High	Low	21d/11.3mA	19f/09.9mA	200	24.6
High	Low	21d/11.3mA	19f/09.9mA	200	24.6
High	Low	21d/11.3mA	19f/09.9mA	200	24.6
High	Low	21d/11.3mA	19f/09.9mA	200	24.6
High	Low	21d/11.3mA	19f/09.9mA	200	24.6
High	Low	21d/11.3mA	19f/09.9mA	200	24.6

Columns are:

- **Input 1** State of the Input 1 signal.
- **Input 2** State of the Input 2 signal
- **SetPt Input** Analog input 1 ADC reading (0 to 3ff) and the associated analog input current. A 20mA input maps to the Maximum Flow Rate.
- **SAR Input** Analog input 2 ADC reading (0 to 3ff) and the associated analog input current. This input monitors the shaping air return (SAR) pressure.
- **sLPM** Average uncalibrated “raw” flow rate reported by the flow meter via the RS422 interface.
- **PSI** Absolute pressure reported by the flow meter via the RS422 interface.

Press Escape or X to return to the Installation Testing menu.

4.8.7.8 Flow Meter Trace

Selecting this option allows the display of the raw data arriving at the AFC-400 from the attached flow meter.

```
Flow Meter Trace

[space bar] toggles trace on/off
Any other key exits tracing.

Press space bar to start:
```

Use this display to determine if the RS422 connection with the flow meter is working properly.

4.8.8 System Calibration

The System Calibration is used to relate all of the air flow control parameters to each other. This is done using a table of 10 set points. For each set point, the AFC-400 records the pressure, flow rate, analog input and output current, as well as readings of both the installed flow/pressure meter, as well as a reference flow/pressure meter used to calibrate the system.

```

AirFlow A System Integration Calibration

      SetPoint  Observed  Input  Output  Meter  Meter  SAR  SAR
      PSI      sLPM      mA     mA     PSI   sLPM   mA   PSI
A:  14.2      000      00.0  00.0   14.2  000   04.0 0.00
B:  20.0      130      00.0  05.4   20.1  130   04.3 1.09
C:  25.0      190      00.0  06.2   25.0  193   04.6 2.11
D:  30.0      250      00.0  07.0   30.0  249   04.9 3.28
E:  27.0      215      00.0  06.5   27.0  214   04.7 2.56
F:  00.0      000      00.0  00.0   00.0  000   00.0 0.00
G:  00.0      000      00.0  00.0   00.0  000   00.0 0.00
H:  00.0      000      00.0  00.0   00.0  000   00.0 0.00
I:  00.0      000      00.0  00.0   00.0  000   00.0 0.00
J:  00.0      000      00.0  00.0   00.0  000   00.0 0.00
Z:  Clear Table
X:  Exit

Select Setpoint to Calibrate [A..J,X]:
  
```

The system is calibrated by pressing the letter (A-J) corresponding to a row in the table. The AFC-400 then warns that this operation should not be undertaken while the system is working, and then prompts for a set point pressure.

```

Select Setpoint to Calibrate [A..J,X]: A

*** Warning - calibration overrides air flow control ***

OK to suspend air flow control?

  A - Yes
  B - No

Select [A..B]: A

AirFlow A Setpoint A Calibration

Prior to calibration, verify the accuracy of the reference
flow meter and install it into the shaping air system.

Enter Set Point Pressure in PSI:
  
```

The process engineer should choose a set of 10 points that cover the range of pressures they expect to use. For low-pressure use, it is important to run an ambient pressure calibration point where the flow rate is 0 sLPM. After selecting the pressure set point to calibrate, the AFC-400 enters a special transparent mode where either the keyboard or analog input can be used to control the proportional valve setting.

```

Enter Set Point Pressure in PSI:
  40
  
```

```

Adjust analog input current/voltage to achieve 40.0 PSI
or use keyboard keys to adjust pressure.
[=] minimum increase      [-] minimum decrease
[+] larger increase       [_] larger decrease
[u] increase about 0.1mA  [d] decrease about 0.1mA
[U] increase about 1.0mA  [D] decrease about 1.0mA

Press Esc to quit, or press Enter when the reference flow
meter reads 40.0 PSI.

      Input  Output  Meter  Meter
      mA     mA     PSI    sLPM
A:  00.0   04.0   14.4   000

```

At this point, the proportional air valve/transducer is adjusted until the reference flow meter reports the desired set point pressure. When the reference meter displays the set point, press the Enter key on the HyperTerminal to lock in the calibration information. After lock-in, two additional items are needed for calibration – the flow rate measured on the reference flow meter, and the shaping air return pressure displayed on a gauge.

```

Press Esc to quit, or press Enter when the reference flow
meter reads 25.0 PSI.

      Input  Output  Meter  Meter
      mA     mA     PSI    sLPM
A:  09.1   08.9   44.4   298

Enter reference meter flow rate reading (sLPM):
      311

Enter shaping air return pressure reading (PSI):
      4.51

Set Point information successfully updated.

```

After entering the sLPM reading from the reference flow meter and the PSI reading from the shaping air return gauge, the calibration point is complete. The process engineer should then repeat the above steps with a selection of pressure points that cover the range of pressures and flow rates that the system will use when operating.

4.8.9 Learned PV Settings

This option displays proportional valve settings that have been “learned” by the AFC-400.

Whenever a stable set point pressure and flow rate is reached, the AFC-400 remembers the proportional valve/transducer setting. It uses these learned settings to quickly establish the correct pressure and flow rate- much faster than PID alone. After applying the learned settings, the AFC-400 uses a mild PID control loop to make adjustments as needed to the proportional valve to compensate for minor irregularities.

The AFC-400 maintains 10 learned proportional valve settings. It also keeps a record of which settings have been most frequently used to avoid forgetting them.

5 Troubleshooting

The AFC-400 is designed to provide as much information as possible in the case of non-operation or Fault conditions. The AFC-400 is engineered to be highly reliable; fault conditions are likely to be caused by external system issues.

5.1 Setup Problems

These problems usually indicate a problem in the setup:

Symptom	Action / Check
Front panel flow meters and LEDs are off	Indicates that the card has no power. <ul style="list-style-type: none"> • Check the front panel power switch. • Check AC power to rack and the card slot. • Check the main power fuse. • Look for bent power pins. • Verify that card is fully seated into the rack.
Flow meter display shows “-0-”	Indicates that the AFC-400 is not receiving flow/pressure updates from the flow meter. <ul style="list-style-type: none"> • Use the Installation Tests > Flow Meter Trace to verify that the AFC-400 is receiving data from the flow meter. • Check that flow meter has power. • Check that the flow meter type is correctly set.
Flow meter display shows “nF “	“No Flow” Indicates that the flow of shaping air is enabled and the flow meter is working, but the flow rate remains at zero. <ul style="list-style-type: none"> • Check the power supply and analog connections to the proportional air valve or pressure transducer. • Possible blockages, kinked hoses, clogged filters. • Verify that the AFC-400 is fully seated in the rack.
Flow meter display shows “HIP“	High Pressure threshold exceeded. <ul style="list-style-type: none"> • PID gain settings may be too big for the system. • Proportional air valve may be stuck open. • Install a flow meter and recheck calibration.
Flow meter display shows “LOP”	Low Pressure threshold exceeded. <ul style="list-style-type: none"> • Verify the air pressure is normal. • Proportional air valve may be stuck closed. • Install a flow meter and recheck calibration.
Flow meter display shows “HIF“	High Flow rate threshold exceeded. <ul style="list-style-type: none"> • Loose hose or other leak

Flow meter display shows “LOF”	<p>Low Flow rate threshold exceeded.</p> <ul style="list-style-type: none"> • Clog or kinked hose • Re-check System Calibration
Flow meter display shows “Hlr”	<p>High Shaping Air Return pressure. Measured shaping air return pressure exceeds expected value.</p> <ul style="list-style-type: none"> • Look for clogging in shaping air nozzles • Check PEA assembly • SA Return Threshold may be too tight. • Re-check System Calibration
Flow meter display shows “LOr”	<p>Low Shaping Air Return pressure. Measured shaping air return pressure is below the expected value.</p> <ul style="list-style-type: none"> • Check system for air leaks. • Verify PEA is correctly assembled and leak-free. • Re-check System Calibration • SA Return Threshold may be too tight.
Flow rate displayed by the AFC-400 is incorrect.	<p>Calibration is probably in error (or has been changed) or there are problems with the attached flow sensor.</p>
Display shows the flow rate varying.	<ul style="list-style-type: none"> • Verify that the proportional valve is not sticking. • Check for leaks. • Look for noise sources on the analog wiring

5.2 System Problems

These problems usually indicate a problem with the AFC-400 itself:

Symptom	Action / Check
Front panel LEDs and flow meter displays flash on and off	Usually means that the microprocessor is malfunctioning. Return the AFC-400 for repair.
Flow meter displays show “FLt” and then the system resets.	Indicates a software problem. Return the AFC-400 for repair.

5.3 Operational Problems

A control fault indicates a problem with the system’s ability to control the speed of a airflow controller. The following table lists some items to check.

Possible Cause	Action / Check
----------------	----------------

Enable Signal	If incorrectly set, the AFC-400 will not start the flow of air, or may open the proportional valve when requested not to.
Low air pressure	Verify that shaping air pressure is sufficient. Recommended pressure is around 100 PSI.
Flow Meter Type	The AFC-400 is designed to operate with either a Universal Flowstream or Alicat V-series or M-series flow meter.
RS-422	Check that the AFC-400 is receiving flow/pressure updates from the flow meter.
PID Gain Settings	The default settings may not be correct for the system. Reduce the gain settings and use the PID Control Monitor to assess how well the control loop is able to manage the flow rate. See section 4.8.1 for more information on PID Control settings.

6 Specifications

6.1 Electrical Specifications

Power Requirements	115/230 VAC +/- 10%, 50/60 Hz., Single Phase
Power Consumption	22 VA Maximum AC
Main Power Fuse	2 AG 2 Ampere Slow Acting
Analog Control Input Voltage	0 to 5 VDC, Z=20k Ohms 0 VDC Input = 000 sLPM 5 VDC Input = Maximum PSI (see section 4.8.2.6)
Current	0 to 20 mA, Z = 250 Ohms 0 or 4 mA = 00.0 PSI 20 mA = Maximum Flow of 999 sLPM Maximum pressure of 99.9 PSI. (PSI * 6.89 = kPa, kPa * 0.145 = PSI)
Relay Contacts Relay 1	4A, 250VAC, Isolated
Relay 2	4A, 250VAC, Isolated

6.2 Mechanical Specifications

Height	10.3", (266.70mm), 6U
Width	2.79", (70.86mm), 14HP
Depth	7.7", (172.50mm)
Weight	4.5lb, 2.0kg
Connectors Rear	A - AMP-650473-5 B - EPT-117-40064-2
Front	DB9-S - AMP 745781-4

7 Connectors and Pin-Outs

7.1 Back Plane Connectors

The rear panel consists of two connectors. These are referred to as A and B. Connector A is above connector B when the AFC-400 is installed. The following sections outline the pin-out of these connectors.

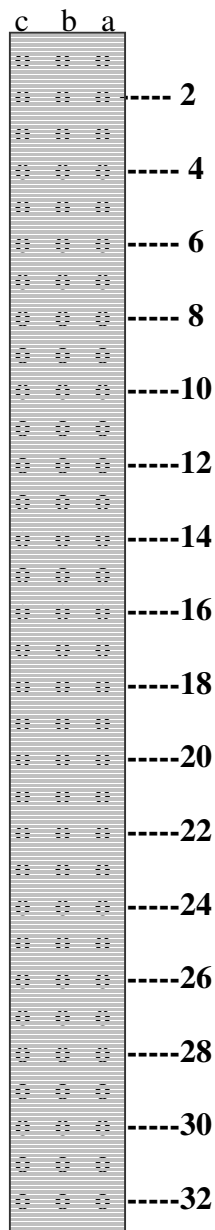

Connector A (Top)
Rear View
Type C

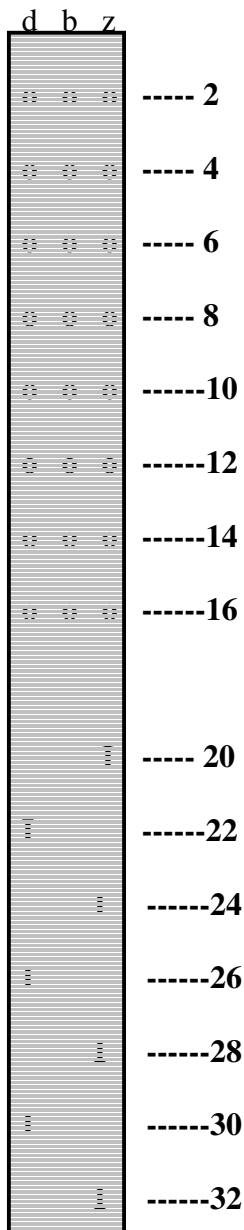

Connector B (Bottom)
Rear View
Mate: EFC 60-1A70

7.2 Connector A Pin out

This connector interfaces the AFC-400 to the rest of the painting system.

Connector A				
	Row	C	B	A
A I R F L O W	1	Relay 1 NC (normally closed)	Relay 1 COM (common)	Relay 1 NO (normally open)
	2	Analog Input 1 + (Set Point)	Analog Feedback +	Analog Proportional Valve Control +
	3	Analog Input 1 – (Set Point)	Analog Feedback -	Analog Proportional Valve Control -
	4	Counter Input –	Counter Input +	Supply +24V
	5	Relay 2 NC	Relay 2 COM	Relay 2 NO
	6	Input 1&2 Common Ground	Input 2 +	Input 1 (0 - 5 to 24V)
	7	Analog Input 2 + (SAR)	RS422 RX +	24V+
	8	Analog Input 2 – (SAR)	RS422 RX -	Ground
A I R F L O W	9	Relay 1 NC (normally closed)	Relay 1 COM (common)	Relay 1 NO (normally open)
	10	Analog Input 1 + (Set Point)	Analog Feedback +	Analog Proportional Valve Control +
	11	Analog Input 1 – (Set Point)	Analog Feedback -	Analog Proportional Valve Control -
	12	Counter Input –	Counter Input +	Supply +24V
	13	Relay 2 NC	Relay 2 COM	Relay 2 NO
	14	Input 1&2 Common Ground	Input 2 +	Input 1 (0 - 5 to 24V)
	15	Analog Input 2 + (SAR)	RS422 RX +	24V+
	16	Analog Input 2 – (SAR)	RS422 RX -	Ground
A I R F L O W	17	Relay 1 NC (normally closed)	Relay 1 COM (common)	Relay 1 NO (normally open)
	18	Analog Input 1 + (Set Point)	Analog Feedback +	Analog Proportional Valve Control +
	19	Analog Input 1 – (Set Point)	Analog Feedback -	Analog Proportional Valve Control -
	20	Counter Input –	Counter Input +	Supply +24V
	21	Relay 2 NC	Relay 2 COM	Relay 2 NO
	22	Input 1&2 Common Ground	Input 2 +	Input 1 (0 - 5 to 24V)
	23	Analog Input 2 + (SAR)	RS422 RX +	24V+
	24	Analog Input 2 – (SAR)	RS422 RX -	Ground
A I R F L O W	25	Relay 1 NC (normally closed)	Relay 1 COM (common)	Relay 1 NO (normally open)
	26	Analog Input 1 + (Set Point)	Analog Feedback +	Analog Proportional Valve Control +
	27	Analog Input 1 – (Set Point)	Analog Feedback -	Analog Proportional Valve Control -
	28	Counter Input –	Counter Input +	Supply +24V
	29	Relay 2 NC	Relay 2 COM	Relay 2 NO
	30	Input 1&2 Common Ground	Input 2 +	Input 1 (0 - 5 to 24V)
	31	Analog Input 2 + (SAR)	RS422 RX +	24V+
	32	Analog Input 2 – (SAR)	RS422 RX -	Ground

7.3 Connector B Pin out

This connector is used exclusively for AC power.

Connector B			
Row	D	B	Z
1			
2			
3			
4			
5			
6			
7			
8			
9			
10			
11			
12			
13			
14			
15			
16			
20			AC1
21			
22			
23			
24			
25			
26	AC2		
27			
28			
29			
30			
31			
32			Ground

7.4 Communications Cable

Local Data Port (Front Panel)

To PC	AFC-400
DB9-S	DB9-P
1	1
2-----	2
3-----	3
4	4
5-----	5
6	6
7	7
8	8
9	9

7.5 RS232 Communication Parameters

Emulation: VT100 or ANSI
Speed: 9600
Stop Bits: 1
Data Bits: 8
Parity: None
Flow Control: Xon, Xoff

7.6 Save Configuration using HyperTerminal

The following table offers systematic instructions for dumping the AFC-400s configuration and saving it into a file.

Step	Action
1	Connect serial cable to front panel of AFC-400. This cable must have pin 9 disconnected. See section 7.4 for the correct pin-out.
2	Connect 9-pin cable to the appropriate COM port on the PC. This is usually COM1, but not always.
3	Start HyperTerminal. This program is usually stored in Program Files > Accessories > HyperTerminal.
4	In HyperTerminal, goto the menu bar and pull down the File , and choose Properties . In the properties dialog, click on the Settings tab and press the ASCII Setup button. Verify that: <div style="text-align: center;"> All boxes are unchecked Line delay = 2 milliseconds Character delay = 0 milliseconds </div>
5	On the HyperTerminal menu bar, pull down the File menu, choose Properties . On the properties dialog, click on the Configure button. Verify that: <div style="text-align: center;"> Bits per seconds = 9600 Data bits = 8 Parity = None Stop bits = 1 Flow control = Xon / Xoff </div>
6	Press the ESC key. You should see text scroll up. Press ESC until the top-level menu is displayed. <pre style="margin-left: 40px;"> AFC-400 Monitor Menu - V2.xx A - AirFlow A B - AirFlow B C - AirFlow C D - AirFlow D E - System Control Select [A..E]: </pre>
7	Press E to go to the System Control menu <pre style="margin-left: 40px;"> AFC-400 System Control - Version 2.xx A - AirFlow A B - AirFlow B C - AirFlow C D - AirFlow D E - Display Event Log F - Dump Configuration G - Load Configuration H - Save Configuration I - System Restart X - Exit Select [A..I,X]: </pre>

8	<p>Press F to dump the configuration</p> <p style="text-align: center;">Prepare PC/HyperTerminal to receive configuration file.</p> <p style="text-align: center;">Press any key to continue:</p>
9	<p>On HyperTerminal menu bar, pull down Transfer and select Capture Text. In the dialog box, enter the name of the file you want to create to contain the configuration dump. A name like “3C3_Afc400.txt” is recommended; as it identifies the location of the air flow controller as well as identifying this file as belonging to an AFC-400. The .txt extension tells HyperTerminal that this is a plain text file.</p>
10	<p>After the file name is in place, press the Start button</p>
11	<p>Press the Enter key to start the dump. You should see text scroll by quickly.</p>
12	<p>When the text stops – move the mouse up to the HyperTerminal menu bar, pull down Transfer, move the cursor down to Capture Text, then slide over and click on Stop. This will close the captured text file and write it to disk on the PC.</p>
13	<p>Press Enter on the keyboard. You should see the System Control menu scroll up.</p>

7.7 Recovering Configuration using HyperTerminal

The following table contains step-by-step instructions for loading a saved configuration file into an AFC-400. Please see the previous section for details on how to save a configuration file.

Step	Action
1	Connect serial cable to front panel of AFC-400. This cable must have pin 9 disconnected. See section 7.4 for the correct pin-out.
2	Connect 9-pin cable to the appropriate COM port on the PC. This is usually COM1, but not always.
3	Start HyperTerminal. This program is usually stored in Program Files > Accessories > HyperTerminal.
4	In HyperTerminal, go to the menu bar and pull down the File , and choose Properties . In the properties dialog, click on the Settings tab and press the ASCII Setup button. Verify that: <p style="text-align: center;">All boxes are unchecked Line delay = 2 milliseconds Character delay = 0 milliseconds</p>
5	In HyperTerminal, go to the top and pull down the File menu, choose Properties . On the properties dialog, click on the Configure button. Verify that: <p style="text-align: center;">Bits per seconds = 9600 Data bits = 8 Parity = None Stop bits = 1 Flow control = Xon / Xoff</p>
6	Press the <i>ESC</i> key. You should see text scroll by. Press <i>ESC</i> until the top-level menu is displayed. <pre style="text-align: center;"> AFC-400 Monitor Menu - V2.xx A - AirFlow A B - AirFlow B C - AirFlow C D - AirFlow D E - System Control Select [A..E]: </pre>
7	Press <i>E</i> to go to the System Control menu <pre style="text-align: center;"> AFC-400 System Control - Version 2.xx A - AirFlow A B - AirFlow B C - AirFlow C D - AirFlow D E - Display Event Log F - Dump Configuration G - Load Configuration H - Save Configuration I - System Restart X - Exit Select [A..I,X]: </pre>

8	<p>Press G to load the configuration. The AFC-400 should display:</p> <pre>Ready to receive configuration file</pre>
9	<p>On HyperTerminal menu bar, pull down Transfer and select Send Text File. In the dialog box, left click on the file that contains the AFC-400 configuration that you want to recover. Press Open to start sending the file to the AFC-400.</p>
10	<p>After the configuration is sent, the AFC-400 will display its top-level menu:</p> <pre>AFC-400 Monitor Menu - V2.xx A - AirFlow A B - AirFlow B C - AirFlow C D - AirFlow D E - System Control Select [A..E]:</pre>

7.8 Upgrading Software using HyperTerminal

The following table contains step-by-step instructions for downloading new software into a AFC-400. Prior to starting, copy the download file (usually named like Afc2xx.txt) into the PC's fixed disk. If using HyperTerminal, it is recommended to copy the file into the Program Files > Accessories > HyperTerminal directory prior to starting the download.

Step	Action
1	Connect serial cable to front panel of AFC-400. This cable must have pin 9 disconnected. See section 7.4 for the correct pin-out.
2	Connect serial cable to the appropriate COM port on the PC. This is usually COM1, but not always.
3	Start HyperTerminal. This program is usually stored in Program Files > Accessories > HyperTerminal.
4	In HyperTerminal, go to the menu bar and pull down the File , and choose Properties . In the properties dialog, click on the Settings tab and press the ASCII Setup button. Verify that: <div style="text-align: center;"> All boxes are unchecked Line delay = 2 milliseconds Character delay = 0 milliseconds </div>
5	In HyperTerminal, go to the top and pull down the File menu, choose Properties . On the properties dialog, click on the Configure button. Verify that: <div style="text-align: center;"> Bits per seconds = 9600 Data bits = 8 Parity = None Stop bits = 1 Flow control = Xon / Xoff </div>
6	On the keyboard, press the ESC key. You should see text scroll up. Press Esc until the top-level menu is displayed. <pre style="margin-left: 40px;"> AFC-400 Monitor Menu - V2.xx A - AirFlow A B - AirFlow B C - AirFlow C D - AirFlow D E - System Control Select [A..E]: </pre>

7	<p>Press E to go to the System Control menu</p> <pre>AFC-400 System Control - Version 1.xx A - AirFlow A B - AirFlow B C - AirFlow C D - AirFlow D E - Display Event Log F - Dump Configuration G - Load Configuration H - Save Configuration I - System Restart X - Exit Select [A..I,X]:</pre>
8	<p>Press I to perform a system restart. The AFC-400 will reset and run its boot monitor software. Inside the AFC-400, this software is kept separate from the operational software and is used for downloading new software. The monitor menu looks like:</p> <pre>System Monitor- V2.xx A - Download Program B - Set Factory Configuration Select [A..B]:</pre> <p>Select option A to prepare the AFC-400 to receive the new software. Option B is intended as a means to work around the possibility of a damaged configuration that causes the system to reset.</p>
9	<p>Press A to prepare the AFC-400 to receive the new software file. The AFC-400 will reply that it is ready to receive the file. The file is a text file, which contains the program image in the form of Motorola S-Records.</p> <pre>Start sending S-record file, press [Esc] to abort...</pre>
10	<p>On HyperTerminal menu bar, pull down Transfer and select Send Text File. In the dialog box, left click on the file that contains the program file that you want to download into the AFC-400. Press the Open button to start sending the file to the AFC-400. When the file is transferring, you should see dots displayed on the screen. Each dot represents a line of the S-record file.</p>
11	<p>After the download completes successfully, the AFC-400 will write the program into its flash memory for permanent storage. When complete, it is recommended to restart the system (power cycle) and verify that the card comes up and the front panel displays the correct version number of the new software.</p>