



SYSTEMS, INC.

SPRAYING TOMORROW'S TECHNOLOGY®

ED26V

**ROBOT MOUNTED DUAL HEAD
AIR ATOMIZING ELECTROSTATIC GUN**

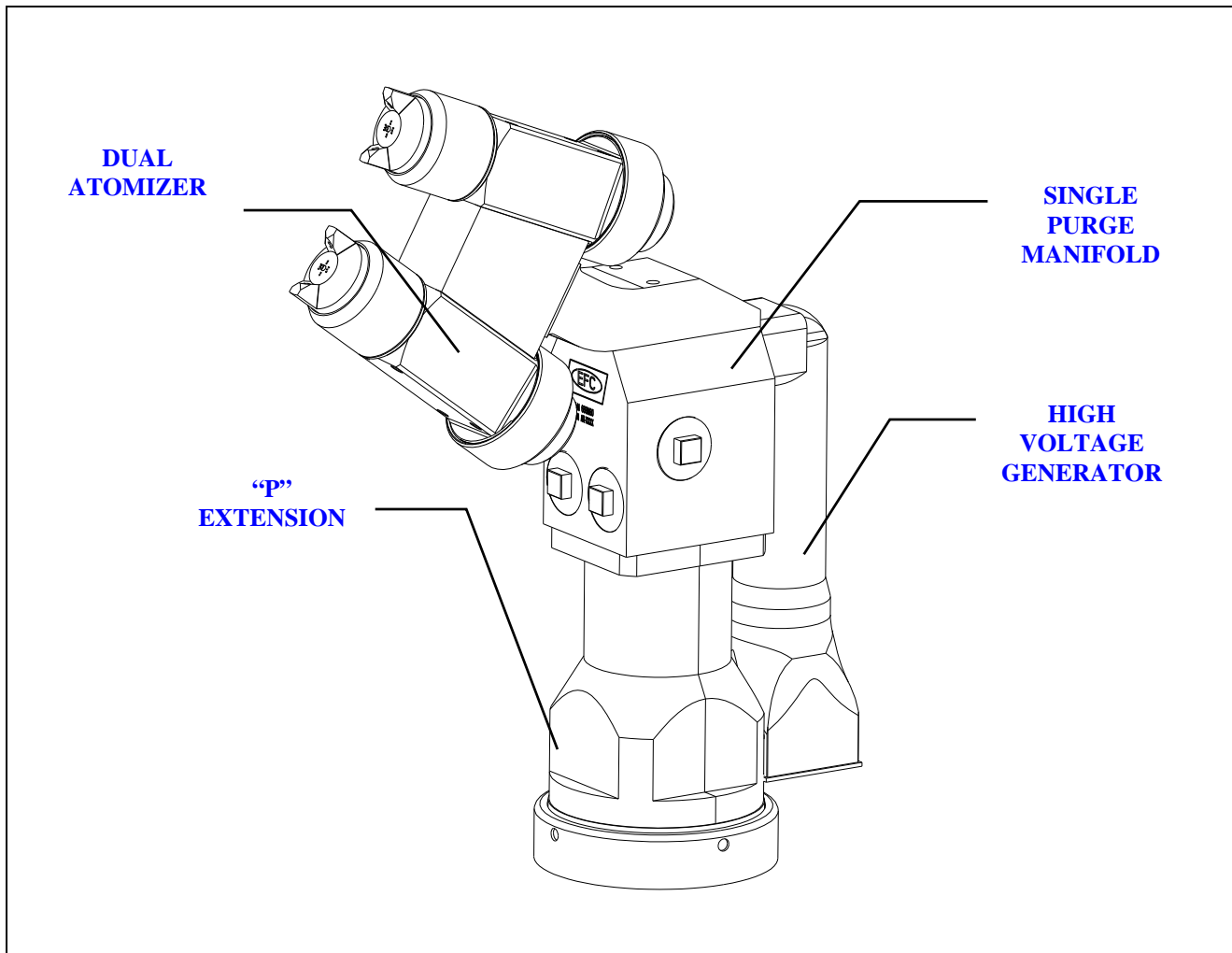

The ED26V is designed for electrostatic applications of solvent based, waterborne high solids and clear coat paints. Engineered from high performance thermoplastic polymers, this light weight unit is normally carried by a robot arm. The ED26V consists of the following:

- A. Dual Air Atomizing Guns with unique piston design allowing total control of Fan Air , Atomizing Air and Fluid Delivery.
- B. Manifold and Adapter set at 90° with integral Regulator, Dump and Paint 1, or optional omission of Regulator and Dump, which makes it ideal for 2K applications.
- C. “P” Extension consisting of PTFE Coils, Hoses, Fittings and Q.D. (Quick Disconnect Nut) for fast, safe removal.
- D. High Voltage Generator.

General Characteristics:

Dimensions: See figures below.
 Weight: Approx. 9.5 lb.
 Voltage: 0 to 100 kV adjusted manually or by PC analog input
 Paint Regulation: 100 to 1500 cc/min. (3.5 to 53 oz/min.) by remotely piloted pneumatic input or PC control
 Pilot Trigger: 60-90 psi (4 - 6 bar)
 Pilot Dumps: 60-90 psi (4 - 6 bar)
 Atomizing Air: 0-75 psig (0 - 5 bar)
 Fan Air: 0-75 psig (0 - 5 bar)
 Spray Pattern Size: 7” to 26” converging into a single pattern
 Restrictor Sizes: 1.00 mm - 3.00mm
 Air Cap: 4 configurations available
 All wetted parts are constructed from: Polyacetal, 316 Stainless Steel and PTFE

Air Characteristics:

Maximum Pressure: 90 psi (6 bar)
 Maximum Flow Rate: 36 scfm (60 Nm³/hr)

High Voltage Characteristics:

Maximum Voltage: 100 kV
 Maximum Current: 200 μAmp
 Maximum Peak Current Per Gun: 100 μAmp
 Maximum Constant Current: 60 - 70 μAmp

