



SYSTEMS, INC.

SPRAYING TOMORROW'S TECHNOLOGY®

ES26

**ROBOT MOUNTED DUAL HEAD
AIR ATOMIZING ELECTROSTATIC GUN**

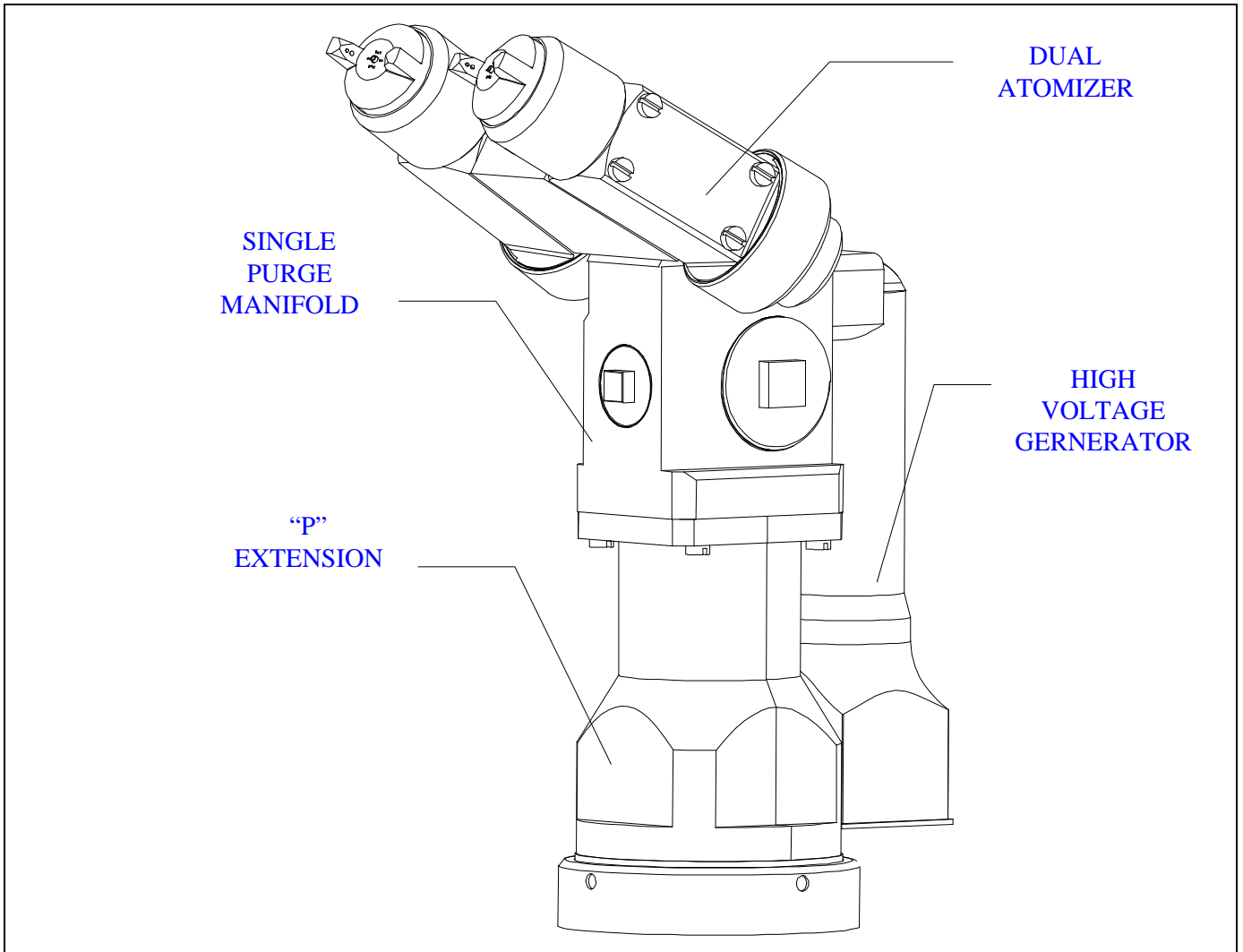

The ES26 is designed for electrostatic applications of solvent based, waterborne high solids and clear coat paints. An engineered form high performance thermoplastic polymer, this light weight unit is normally carried by a robot arm. The ES26 consists of the following:

- A. Dual Air Atomizing Guns with unique piston design allowing total control of Fan Air, Atomizing Air and Fluid Delivery.
- B. Manifold and Adapter set at 60° with integral Regulator, Dump and Paint 1, or optional omission of Regulator and Dump which makes it ideal for 2K applications.
- C. "P" Extension consisting of PTFE Coils, Hoses, Fittings and Q.D. (Quick Disconnect Nut) for fast, safe removal.
- D. High Voltage Generator.

General Characteristics:

Dimensions: See figures below.
 Weight: Approx. 9.5 lb.
 Voltage: 0 to 100 kV adjusted manually or by PC analog input
 Paint Regulation: 100 to 1500 cc/min. (3.5 to 53 oz/min.) by remotely piloted pneumatic input or PC control
 Pilot Trigger: 60-90 psi (4 - 6 bar)
 Pilot Dumps: 60-90 psi (4 - 6 bar)
 Atomizing Air: 0-75 psig (0 - 5 bar)
 Fan Air: 0-75 psig (0 - 5 bar)
 Spray Pattern Size: 7" to 26" converging into a single pattern
 Restrictor Sizes: 1.00 mm - 3.00mm
 Air Cap: 4 configurations available
 All wetted parts are constructed from: Polyacetal, 316 Stainless Steel and PTFE

Air Characteristics:

Maximum Pressure: 90 psi (6 bar)
 Maximum Flow Rate: 36 scfm (60Nm³/hr)

High Voltage Characteristics:

Maximum Voltage: 100 kV
 Maximum Current: 200 μA
 Maximum Peak Current per Gun: 100 μA
 Maximum Constant Current: 60 - 70 μAmp

Transfer Efficiency:

Non-electrostatic 30% - 40%
 Electrostatic 50% - 60%

