



SYSTEMS, INC.

SPRAYING TOMORROW'S TECHNOLOGY®

ES29SWO

ROBOT MOUNTED DUAL HEAD
AIR ATOMIZING ELECTROSTATIC GUN

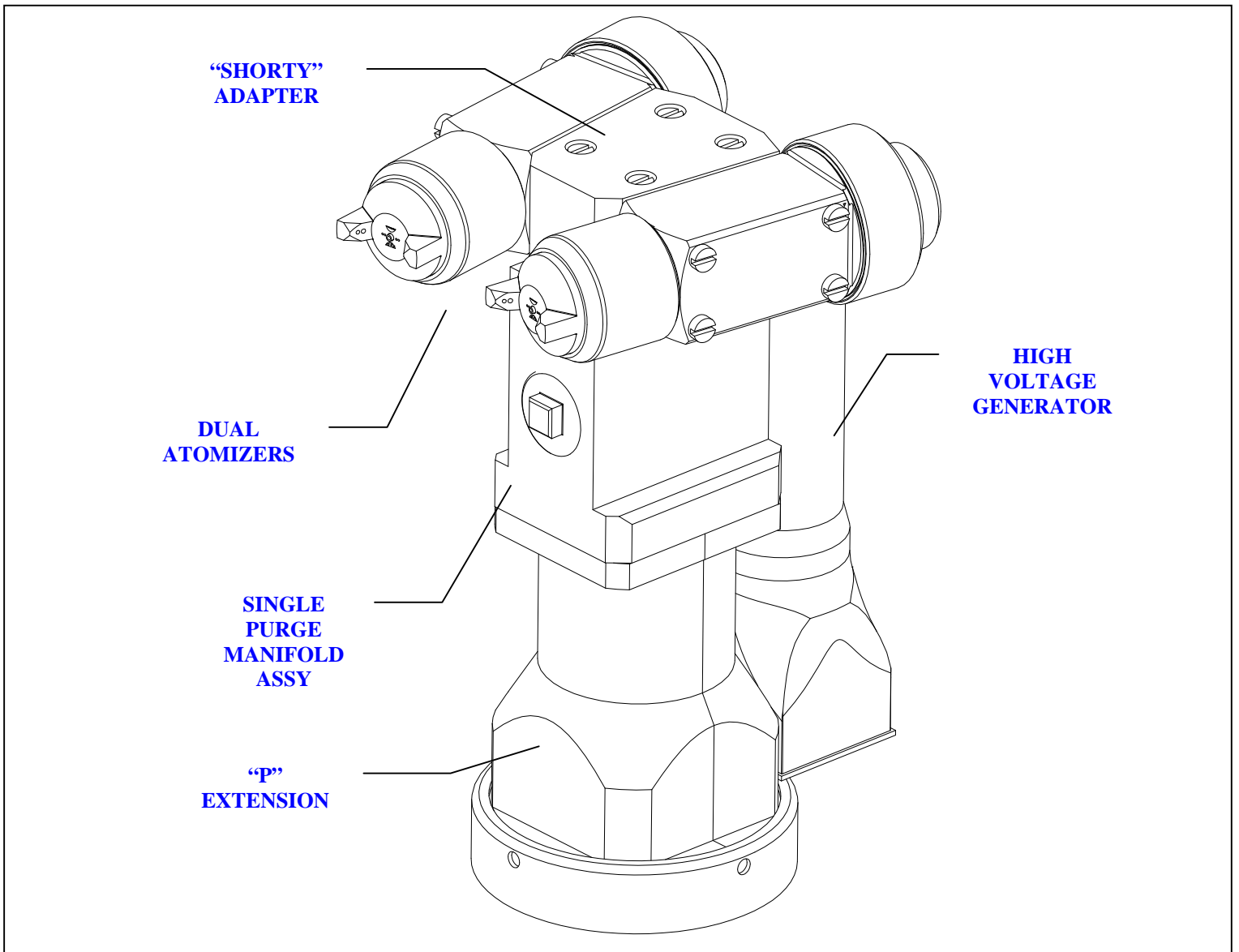

The ES29SWO is designed for electrostatic applications of solvent based, waterborne high solids and clear coat paints. Engineered from high performance thermoplastic polymers, this light weight unit is normally carried by a robot arm. The ES29SWO consists of the following:

- A. Dual Air Atomizing Guns with unique piston design allowing total control of Fan Air, Atomizing Air and Fluid Delivery.
- B. Shortened Adapter and Manifold with integral Dump and Paint 1, or optional omission of Dump.
- C. "P" Extension consisting of PTFE Coils, Hoses, Fittings and Q.D. (Quick Disconnect Nut) for fast, safe removal.
- D. High Voltage Generator.

General Characteristics:

Dimensions: See figures below.
 Weight: Approx. 9.5 lb.
 Voltage: 0 to 100 kV adjusted manually or by PC analog input
 Paint Regulation: 100 to 1500 cc/min. (3.5 to 53 oz/min.) by remotely piloted pneumatic input or PC control
 Pilot Trigger: 60-90 psi (4 - 6 bar)
 Pilot Dumps: 60-90 psi (4 - 6 bar)
 Atomizing Air: 0-75 psig (0 - 5 bar)
 Fan Air: 0-75 psig (0 - 5 bar)
 Spray Pattern Size: 7" to 26" converging into a single pattern
 Restrictor Sizes: 1.00 mm - 3.00mm
 Air Cap: 4 configurations available
 All wetted parts are constructed from: Polyacetal, 316 Stainless Steel and PTFE

Air Characteristics:

Maximum Pressure: 90 psi (6 bar)
 Maximum Flow Rate: 36 scfm (60 Nm³/hr)

High Voltage Characteristics:

Maximum Voltage: 100 kV
 Maximum Current: 200 μA
 Maximum Peak Current per Gun: 100 μA
 Maximum Constant Current: 60 - 70 μA

