



SYSTEMS, INC.

MAINTENANCE MANUAL  
FOR EFC BELL CUPS WITH  
SCREW-IN INSERT ASSEMBLIES

**All statements, information, and data presented herein are believed to be accurate and reliable but are presented without warranty, guaranty, or responsibility of any kind, expressed or implied. Statements or suggestions regarding possible use of our products are made without representation or warranty that any such use is free of patent infringement, and we are not intending to infringe on any patent. The user should not assume that all safety measures are indicated or that other measures may not be required. Tekrez is a registered trademark of EFC SYSTEMS, INC. VITON® is a registered trademark of DUPONT DOW ELASTOMERS. TEFLON® is a registered trademark of the DUPONT COMPANY.**

# **1. INTRODUCTION**

## **1.1 General Description**

EFC bell cups are designed to electrostatically apply solvent borne and water based paint used in the automotive and related industries. Bell cups used to apply powder are also offered, but are not covered in this manual.

It is important to read and fully understand this maintenance manual, before installing, operating and maintaining EFC bell cups. Operators of these bell cups must be especially aware of all safety considerations involved. This manual should be kept in a safe location that is easily accessible to everyone involved with these bell cups.

It is the responsibility of the end user of this system to ensure that all local, state and federal laws and regulations concerning safety are followed, including but not limited to fire and environmental codes, building codes, as well as occupational safety and health acts.

## **1.2 Copyrights**

All rights are reserved by EFC SYSTEMS, INC. Proprietary technical information and drawings are contained in this manual. This document and parts herein must not be reproduced or copied without EFC SYSTEMS, Inc's written permission. The contents must not be imparted to a third party nor be used for any unauthorized purpose.

### 1.3 Precautionary Symbols



**DANGER!** – An alert to a health hazard that could result in serious bodily injury or death.



**WARNING!** – An alert to a hazardous situation that could result in serious bodily injury and/or serious equipment damage.



**CAUTION!** – An indication that extra precautions should be taken to prevent bodily injury or equipment damage.



**TIP** – An indication of some useful information when working with EFC bell cups.

## 2. SAFETY

All personnel who operate and maintain the equipment presented within this manual must to be fully trained on the safety guidelines that must be followed concerning this equipment and the environment in which this equipment is operated.

### 2.1 Experience



**DANGER!** All those involved with the operation and maintenance of these bell cups need to have the expertise and experience to do so. Severe injury or death may result from unqualified individuals who attempt to operate or handle this equipment. An electrical shock, fire or explosion may also occur if this warning is not followed.

### 2.2 Safety Codes

All personnel involved with the operation and maintenance of the bell cups, and the environment in which they operate, must understand and follow all local, state and federal laws and regulations concerning safety, including but not limited to fire and environmental codes, building codes, as well as occupational safety and health acts. Failure to do so could result in bodily injury and equipment damage due to a fire, explosion or electrical shock.

### 2.3 Sparks & Open Flames Within Spray Booth



**DANGER!** All open flames and sources of spark are to be kept out of and away from the spray booth and the areas in which bell cup cleaning is performed. Failure to do so could result in the ignition of a flammable substance, creating a fire and explosion hazard

## 2.5 Personnel Safety



### **WARNING! Ventilation**

Adequate ventilation must be maintained at all times when working with and maintaining EFC bell cups. Without proper ventilation, noxious fumes from paints and solvents as well as ozone gas may build to unsafe levels, causing poisoning, bodily irritations and fire and explosion hazards.



### **CAUTION! Protective Gear**

Adequate protective gear must be worn at all times when maintaining the bell cups. Protective gear should include safety glasses that are impact resistant, electrostatic work shoes, work clothing and ear protection, gloves and respirators.

## 2.6 Improper Use



### **DANGER! Using a Damaged Bell Cup**

If, during the course of maintenance, a damaged bell cup is discovered, do not continue using that bell cup. Operating with a damaged bell cup could result in finished paint defects as well as severe personal injury.

## 2.7 Additional Risks



### **WARNING! Abnormal Phenomenon**

If any abnormal instances occur during operation as a result of damaged or poorly maintained bell cups, immediately shut down the system and correct the problem. Abnormal phenomena include but are not limited to: excessive motor vibration, excessive motor noise, and voltage losses. Continuing to operate the atomizer system with obvious problems could lead to bodily injury and equipment damage.

### **System Modifications**

Under no circumstances are personnel to modify EFC bell cups without written permission from EFC SYSTEMS, INC. This also applies to the use of replacement parts and systems other than EFC supply parts. Modifications made to the bell cups could result in bodily injury and equipment loss, and/or a warranty void.

### **Maintenance**

Proper maintenance procedures must be followed according to the maintenance sections of this manual to ensure the safe operation of the bell cups. Failure to follow the maintenance procedures and checks could result in equipment failure and personal injury.

### **Bell Cup Assembly**

It is important to properly attach the bell cup to the motor shaft. The bell cup and motor shaft should be clean and free of debris. Placing the bell cup on the motor, with one or both being dirty, would increase the possibility of the bell cup disconnecting from the motor and injuring someone. A dirty or damaged bell cup could also create an imbalance within the motor assembly, thereby increasing the chances of motor failure.

### 3. MAINTENANCE

#### 3.1 Bell Cup Removal

Ensure the turbine has come to a complete stop before servicing the bell cup. Once the bell cup has stopped moving, carefully remove the bell cup from the air bearing motor by holding atomizer shaft stationary (Use EFC Wrench Part #) and unscrewing the cup counterclockwise from the turbine shaft. Pay special attention to the sharp edge of the bell cup that can easily cause hand lacerations.

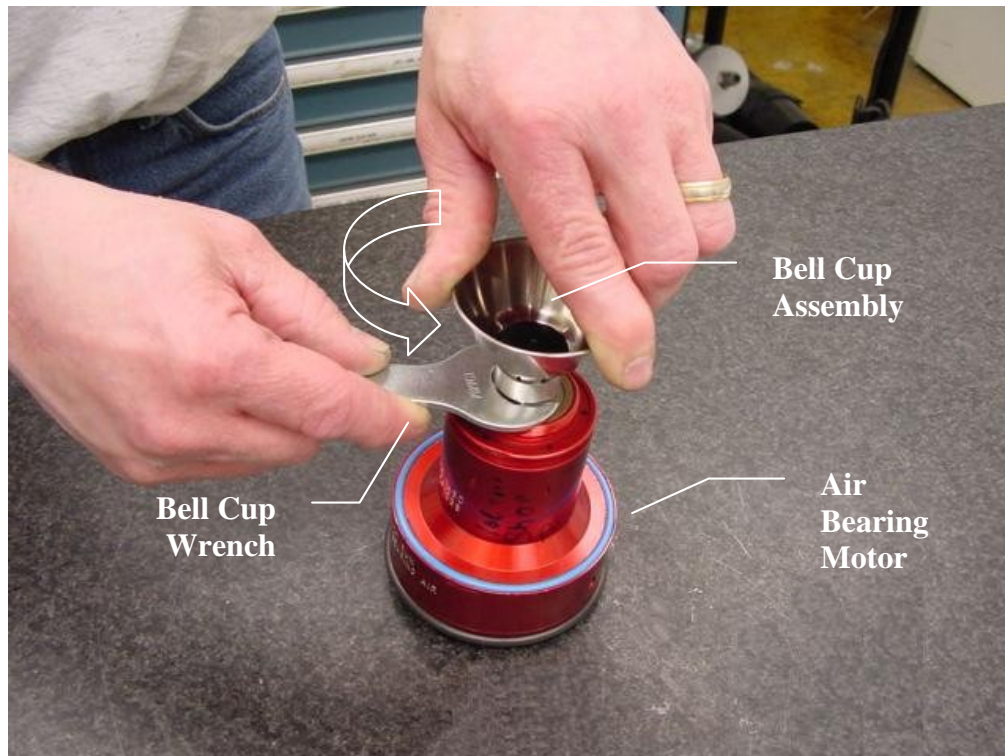

### 3.2 Bell Cup Disassembly

The majority of EFC bell cups are essentially a two-piece design. A center insert screws into the bell cup body to form the bell cup assembly.

Place the bell cup on a surface that will not damage it and carefully remove the cup's insert assembly (Consult EFC for proper tool). The insert assembly may contain more than one piece, so exercise caution when removing the bell cup's center components.

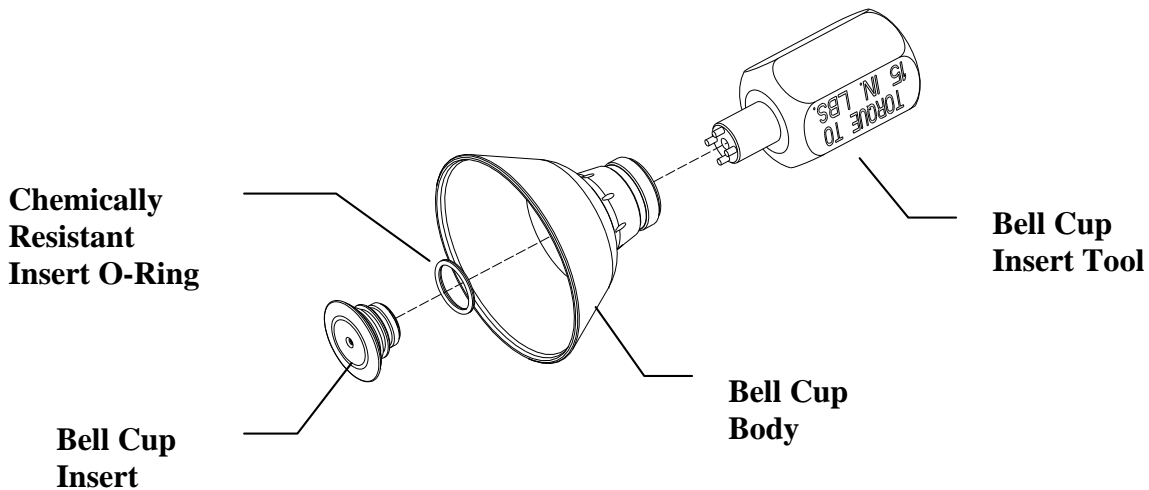
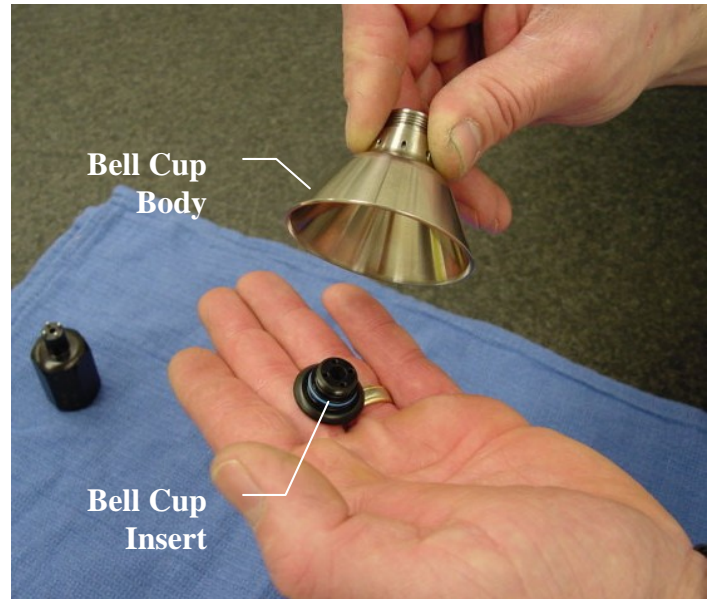

Put the bell cup insert tool in the back of the bell cup as shown above. Turn the wrench clockwise to loosen the insert from the bell cup body.

### 3.3 Bell Cup Inspection

Check the entire bell cup for signs of damage and excessive wear. The outer edge plays a particularly important role in the atomization of the paint, and must be kept free of damage.

Inspect all components for damage (including the chemically resistant o-ring), wear and replace as necessary.

Check the bell cup threads and taper where it mounts to the turbine shaft. Both the taper and threads must be damage and dirt free to ensure it properly secures to the turbine shaft.

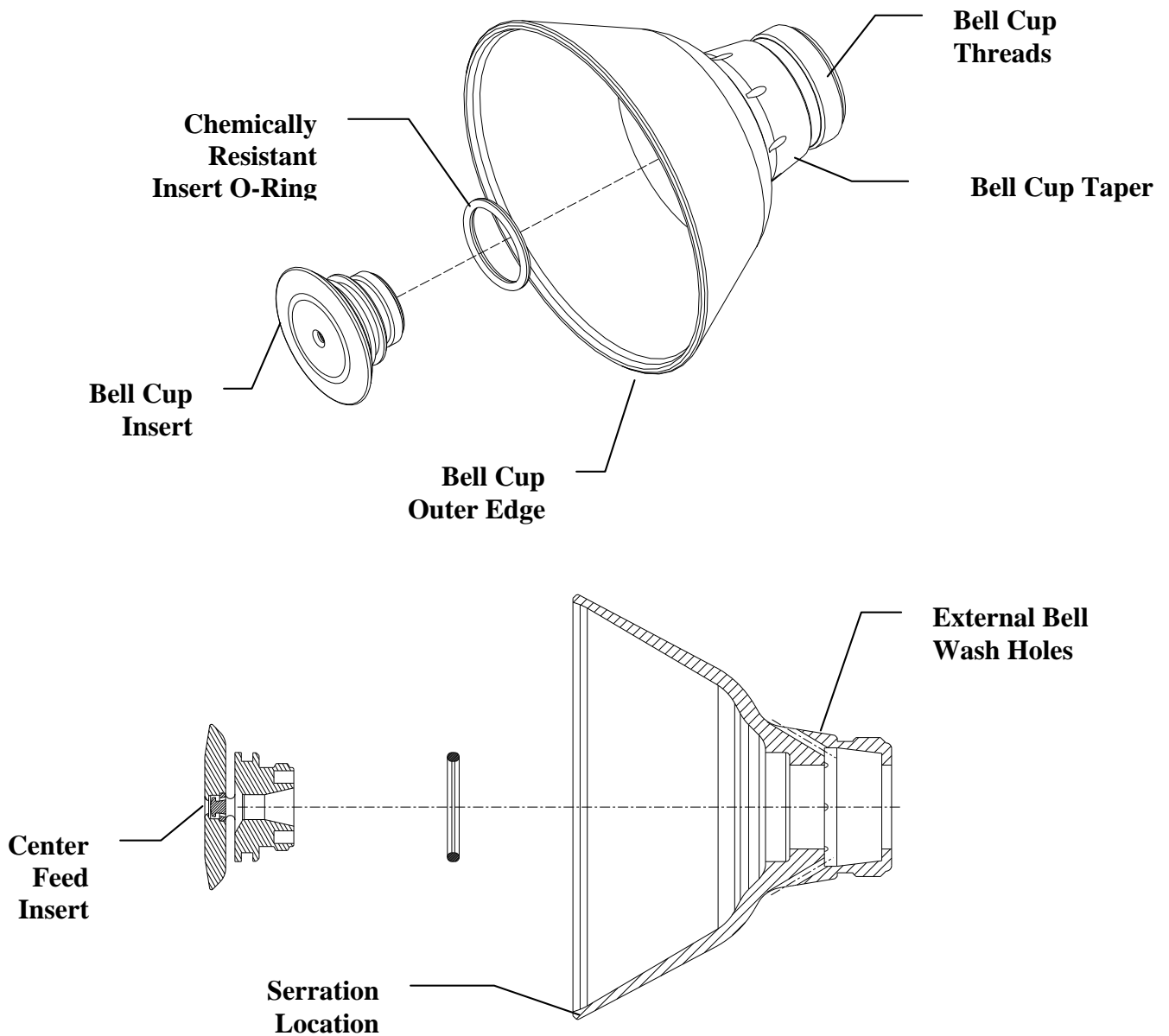

### 3.4 Bell Cup Cleaning

Use your facility's approved solvent to clean the entire cup. Use only soft bristled brushes and lint-free cloths to clean the cup.

Inspect the outer and inner surface of the bell cup. Remove all debris from the entire cup, paying particular attention to the bell cup threads. Remove all debris from within the serrations at the inner exiting edge of the cup.

Also clean the insert assembly with a soft bristle brush. The o-ring on the insert is chemically resistant and may be exposed to aggressive solvents. However, do not soak the o-ring in aggressive solvents for more than one hour and allow it to dry as long as it was soaked. Check the o-ring for damage and replace as necessary.

Remove any paint build-up on the bell cup's taper. The taper engages the motor shaft and should be carefully inspected and cleaned to prevent motor imbalance after reassembling it to the motor.

**Bell Cup  
Serrations**

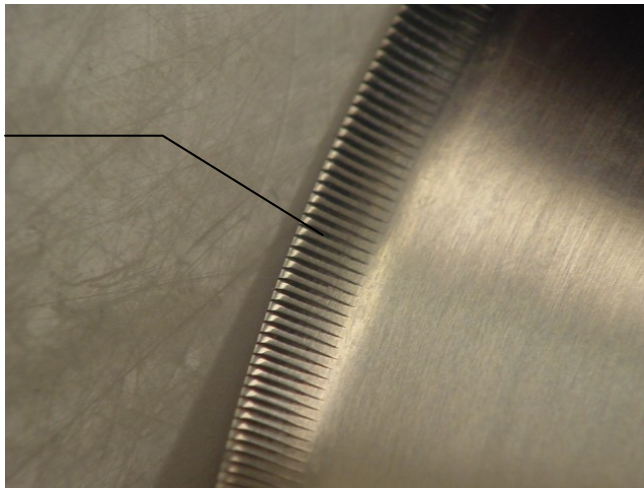

**Paint Debris on  
Bell Cup Insert**

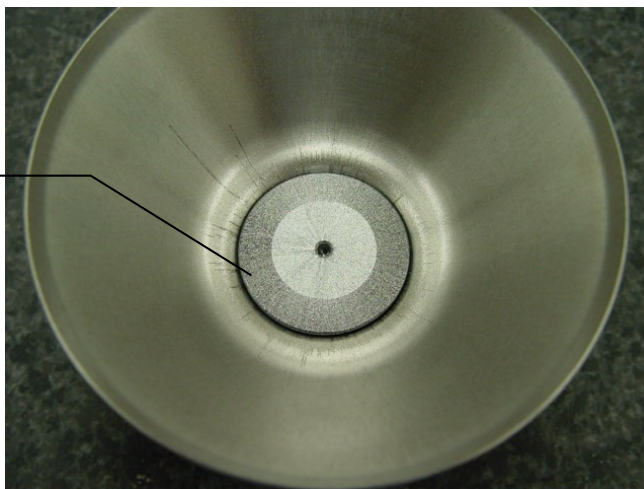

### 3.4 Bell Cup Cleaning (Continued)

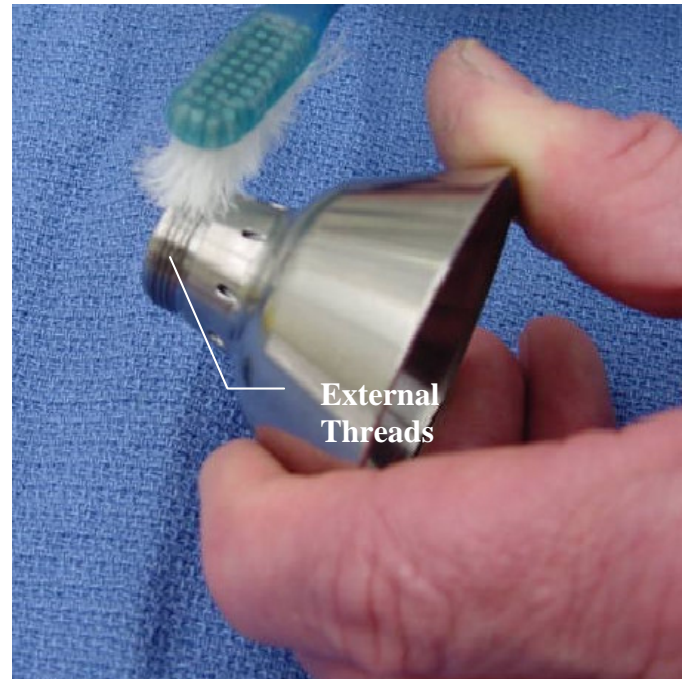
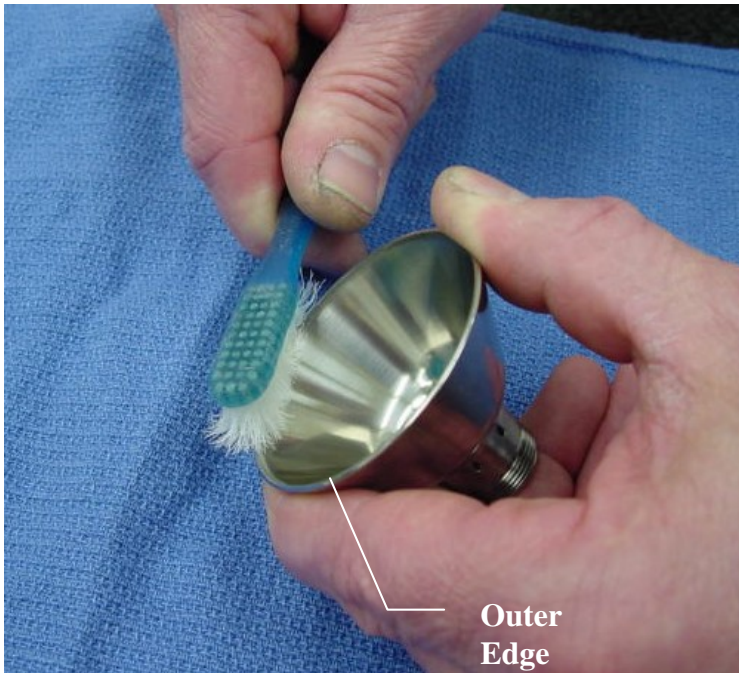

Once the bell cup has been thoroughly cleaned, dry the bell cup body and insert with a clean source of compressed air.

### 3.5 Bell Cup Assembly

Reassemble the bell cup by carefully starting the bell cup insert in the body of the bell cup by hand. Then, use the proper bell cup wrench to tighten. Care must be taken when reinstalling the insert assembly into the bell cup body so the o-ring on the insert is not cut.

With a torque wrench (Consult EFC for proper tool) attached to the insert tool, insert the bell cup insert tool into the back of the bell cup and turn the insert assembly counterclockwise (When viewed from the back of the cup). Set the torque wrench to 15 in-lbs. The insert will come to a stop when it is inserted properly. The bell cup is now ready for use.

### 3.5 Bell Cup Assembly (Continued)

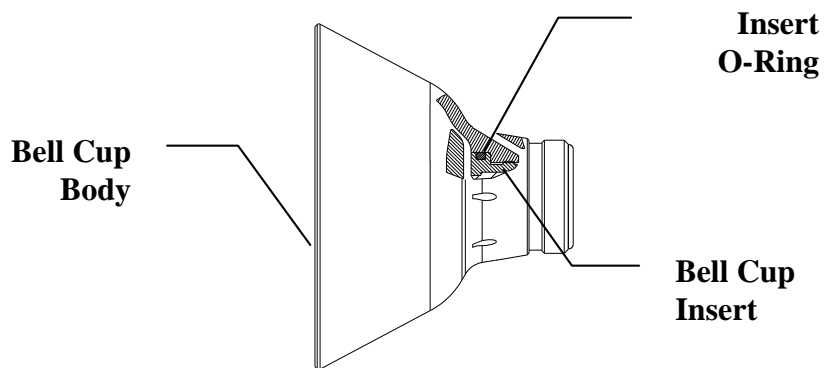
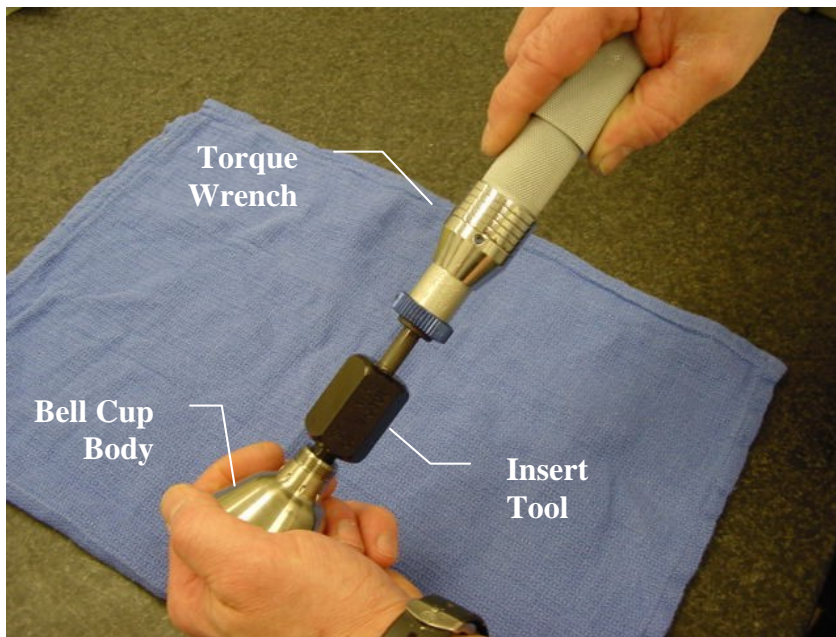

To prevent damage, store the bell cup in a safe place, preferably in its original packaging.