

22-3A70

EFC VB3 REPLACEMENT TURBINE

EFC Rotary Atomizer Turbines provide an average of **25%** air savings over OEM turbines. Our floating carbon bearing and G1.0 balance spec offer a more accurate applicator for material, plant & maintenance savings.



Specifications

- Drop In Replacement for OEM
- Floating Carbon Radial main bearing
- Tekrez® Chemical Resistant O-rings
- Proprietary Shaping Air Flow
- Redesigned front housing with Removable Bearing Cap for a Higher Service Factor
- Vibration-Dampening Design for Long Lasting Maintenance Cycles
- 1 Year EFC Warranty

Compatibility

OEM PN#	E0-6301-022-000A
OEM COLOR	Black Anodized Finish
EFC PN#	22-3A70
EFC COLOR	Black Anodized Finish



EFC SYSTEMS, INC.
1851 CLARK ROAD
HAVRE DE GRACE, MD 21078
+1 800 365-5897
WWW.EFCUSA.COM

SPRAYING TOMORROW'S TECHNOLOGY®



SYSTEMS, INC.

Form No: M 22-3A70 6.2015

© 2015 EFC Systems, Inc. All Rights Reserved. Specification subject to change without notice

22-3A70

FANUC VB3 REPLACEMENT TURBINE OVERVIEW

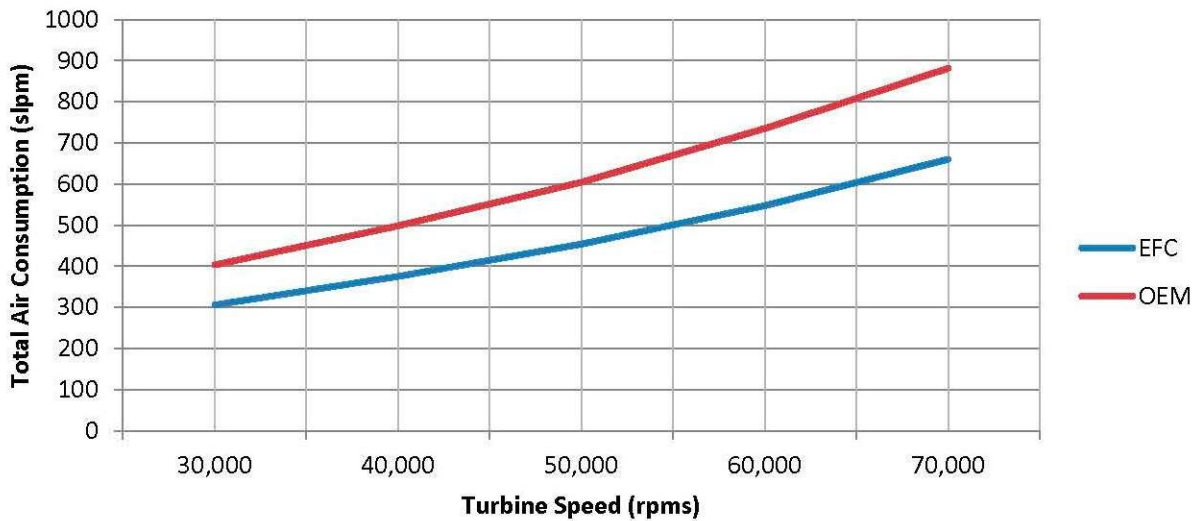
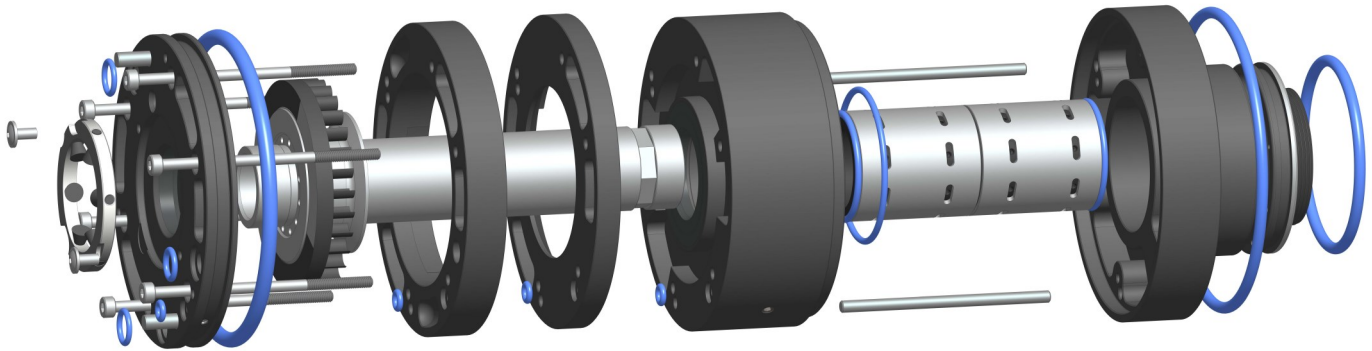
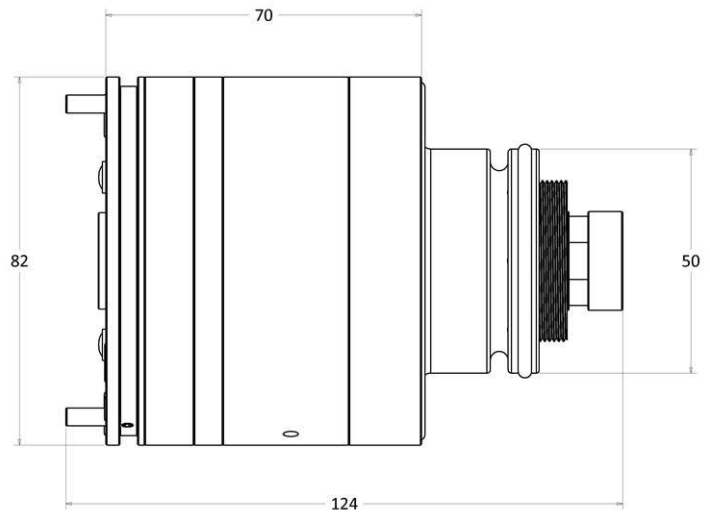

All readings taken using Scientific Flow Meter

EFC SYSTEMS, INC.
1851 CLARK ROAD
HAVRE DE GRACE, MD 21078
+1 800 365-5897
WWW.EFCUSA.COM

SPRAYING TOMORROW'S TECHNOLOGY®

