



SYSTEMS, INC.

FS40R ROTARY ATOMIZER



**1325 POST ROAD
HAVRE DE GRACE, MD 21078
(800) 365-5897 TECHNICAL SUPPORT
Copyright © 2004 EFC Systems, Inc. All Rights Reserved.**

All statements, information, and data presented herein are believed to be accurate and reliable but are presented without warranty, guaranty, or responsibility of any kind, expressed or implied. Statements or suggestions regarding possible use of our products are made without representation or warranty that any such use is free of patent infringement, and we are not intending to infringe on any patent. The user should not assume that all safety measures are indicated or that other measures may not be required. Tekrez is a registered trademark of EFC SYSTEMS, INC. VITON® is a registered trademark of DUPONT DOW ELASTOMERS. TEFLON® is a registered trademark of the DUPONT COMPANY.

All rights are reserved by EFC SYSTEMS, INC. Proprietary technical information and drawings are contained in this document. This document and parts herein must not be reproduced or copied without EFC SYSTEMS, Inc's written permission. The contents must not be imparted to a third part nor be used for any unauthorized purpose.

1. INTRODUCTION

1.1 General Description

The FS40R-SYS is an air bearing rotary atomizer system designed to electrostatically apply solvent borne paint used in the automotive and related industries. It's robust and innovative design allows for ease of removal from hollow wrist robots or reciprocating machines, fast and easy cleaning, superior transfer efficiency and long life. Extensive in-house lab and automotive plant testing and validations have been performed on the FS40R to ensure the highest quality rotary atomizer system possible.

It is important to read and fully understand the FS40R Operation Manual, the UP-200 Service and Operations Manual, the EFC 4x4 Card Cage Installation Manual and the TSC-400 Service and Operations Manual before installing, operating and maintaining the FS40R-SYS. Operators of this atomizer system must be especially aware of all safety considerations and performance specifications involved. Each of these manuals should be kept in a safe location that is easily accessible to everyone involved with this system.

It is the responsibility of the end user of this system to ensure that all local, state and federal laws and regulations concerning safety are followed, including but not limited to fire and environmental codes, building codes, as well as occupational safety and health acts.

1.2 System Modifications

Under no circumstances are personnel to modify the FS40R without written permission from EFC SYSTEMS, INC. This also applies to the use of replacement parts and systems other than EFC supply parts. Modifications made to this system could result in bodily injury and equipment loss, and/or a warranty void.

1.3 Maintenance

Proper maintenance procedures must be followed according to the maintenance sections of the operation manuals to ensure the safe operation of the FS40R. Failure to follow the maintenance procedures and checks could result in equipment failure and personal injury.

1.4 Bearing Air Drop

The FS40R utilizes an air bearing motor, which allows the shaft within the motor to “float” on a thin pocket of air, known as bearing air. To prevent damage to the motor, bearing air should not drop below 80 psi. It is recommended the motor should always have a constant supply of bearing air of at least 85 psi when operating or idling. If the bearing air drops below this setting, the turbine *must be brought to an immediate stop* by discontinuing the drive air and engaging the brake air. The FS40R consumes approximately 2 scfm of bearing air, when bearing air is supplied at 85 psi.

2. FEATURES

- 60° Manifold orientation to allow for easier access within and around the vehicle
- Compact and light weight (Less than 15 lbs.)
- Streamlined profile for ease of cleaning
- Internal fluid regulator (50-1000 ccpm)
- Fluid lines with connection means to prevent fluid lines from contaminating one another
- Highly efficient, self cleaning bell cup assembly
- Aluminum inner and outer shrouds to help reduce the amount of wrap back onto the atomizer
- Nanovalves located within the manifold to provide for internal and external bell wash
- Microvalve dump located within the manifold for quick purges
- Quick disconnect nut to easily and quickly remove the FS40R from the robot mount
- Self-contained air motor for fast and easy replacement
- All motor and Q.D. o-rings are chemically resistant Tekrez® that resist swelling
- Fiber optic speed sensing
- Pneumatic pressure switch for disabling the speed card (i.e. drive air supply) in case of loss of bearing air.

3. SYSTEM COMPONENTS

3.1 Rotary Atomizer

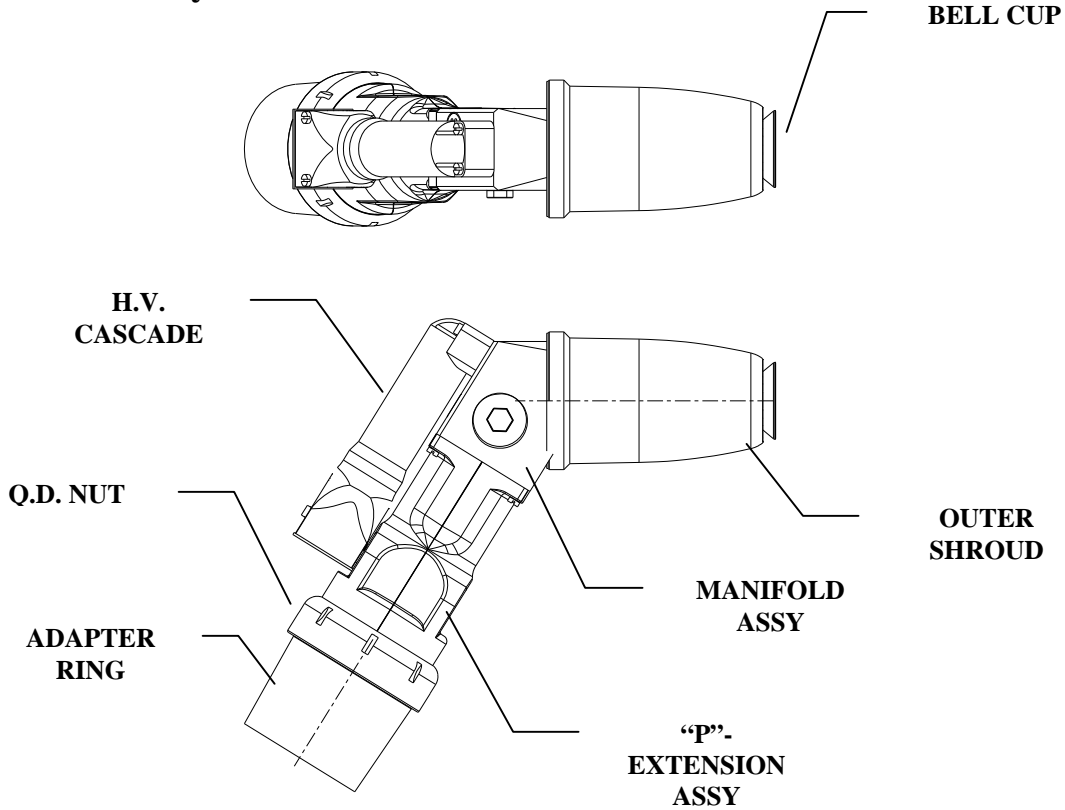

QTY	EFC PN	DESCRIPTION
1	25-1A33K	BELL CUP ASSY
1	250C50	HIGH VOLTAGE CASCADE
1	FS40RP50	P-EXTENSION ASSY
1	15-3A22AL	OUTER SHROUD
1	40-1A31	QUICK DISCONNECT NUT
1	30-1A89	MANIFOLD ASSY
1	45-1A48	ADAPTER RING

3.2a Manifold Assy

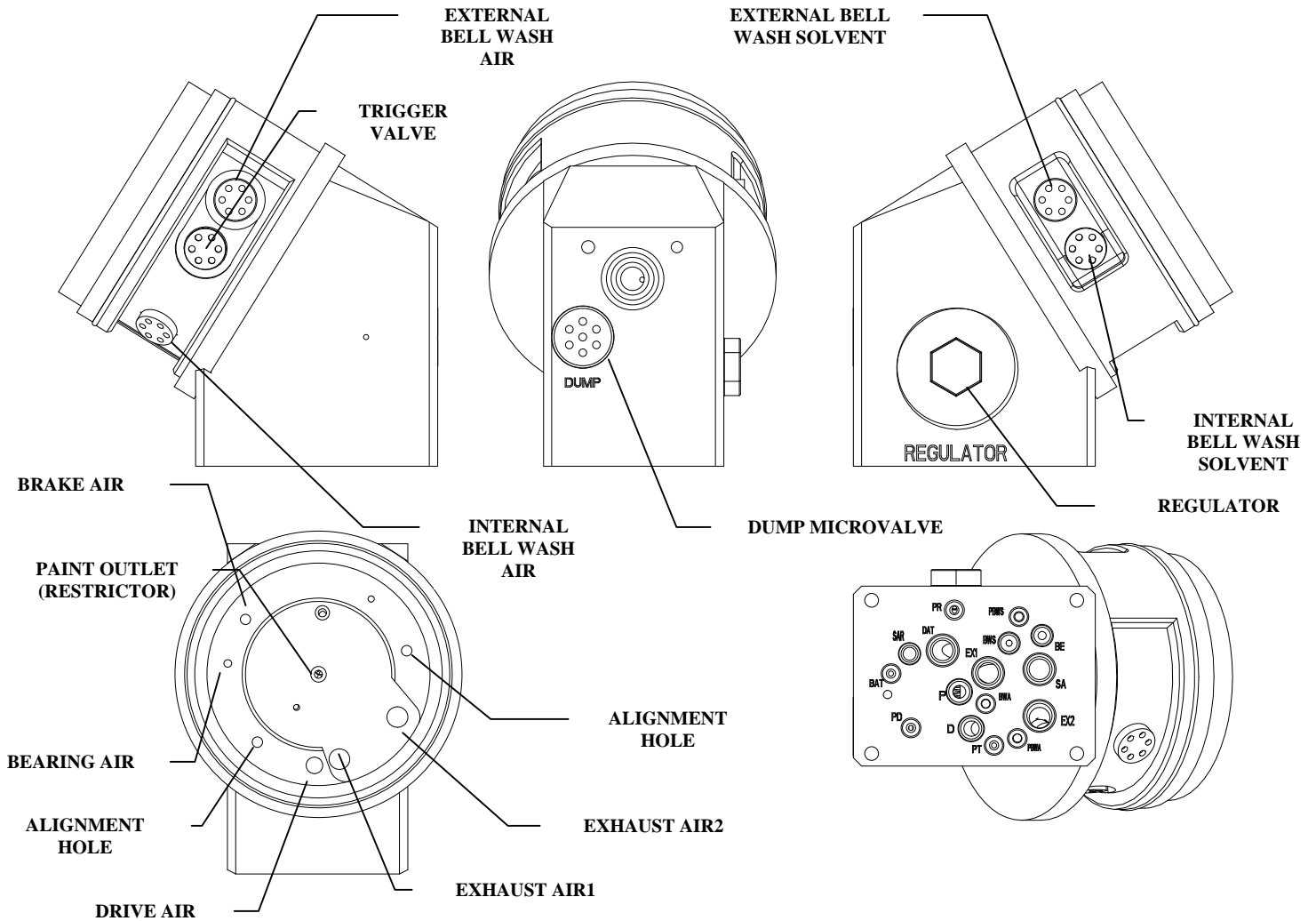

The single purge manifold contains a 0-1000 cc/min regulator cavity, one microvalve dump cavity, five nanovalve cavities for external bell wash solvent, external bell wash air, internal bell wash solvent, internal bell wash air and pilot trigger and a fiber optic sensor with approximately one foot of fiber optic cable. The regulator cavity houses a regulator spring, seat and poppet valve along with a diaphragm, diaphragm holder, spacer and three o-rings. Within the dump cavity is a microvalve assembly and a microvalve seat. Within each nanovalve cavity is a nanovalve assembly and a nanovalve seat.

Fluids are supplied to the bottom of the manifold (through the P-Extension) via push fittings (P.F.). The push fittings allow for easy hose installation and removal. All fluid push fittings (paint, dump and bell wash) are designed to utilize a dual Tekrez® o-ring sealing mechanism. This eliminates the possibility of a fluid leak. All other push fittings contain a single o-ring seal.

3.2b Air Bearing Motor Assy

The EFC air bearing motor is a self contained unit that has been engineered and manufactured to the highest standards. The motor is of the orifice type that allows the shaft, flywheel and bell cup to “float” frictionless on a thin film of air during operation. Bearing air, turbine drive air, brake air and external bell wash enter the back of the motor. Turbine exhaust exits the back of the turbine through four slot openings. The air bearing motor is capable of speeds reaching 80,000 rpm.

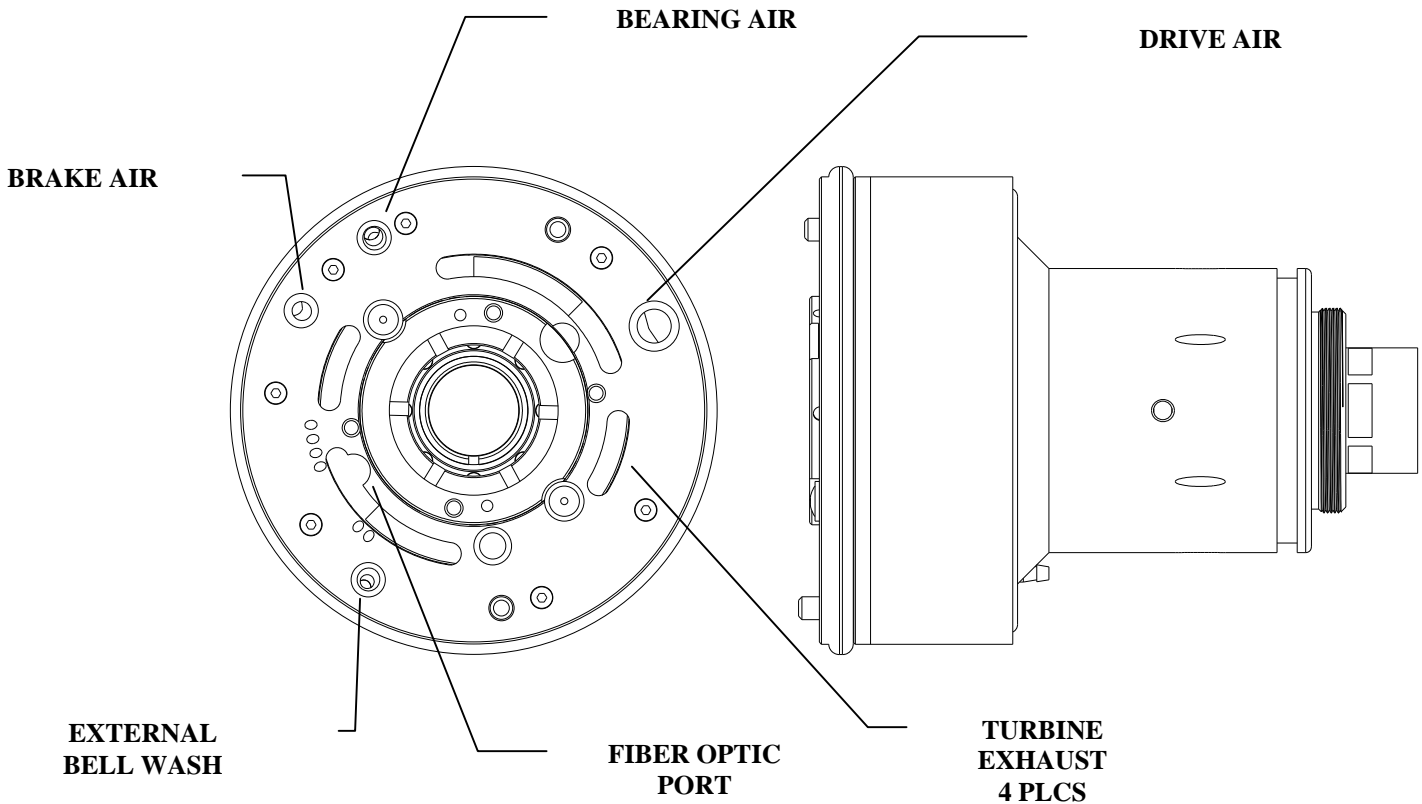

3.2c High Voltage Cascade

A shielded, three wire low voltage cable brings 0-10 VDC up through the hose bundle and into the atomizer assembly. The line is Teflon coated and flexible enough to easily bend and flex with the robot arm during operation. The low voltage is then fed into the High Voltage Cascade, which steps the voltage up to 100,000 volts if necessary. The low voltage cable sends back a feedback signal to the UP-200 Power Supply, informing the UP-200 of tip voltage as well as current draw. The H. V. Cascade mounts to the back of the atomizer assembly via four nylon screws, for easy removal and replacement if necessary.

3.2d Hose Bundle Assy

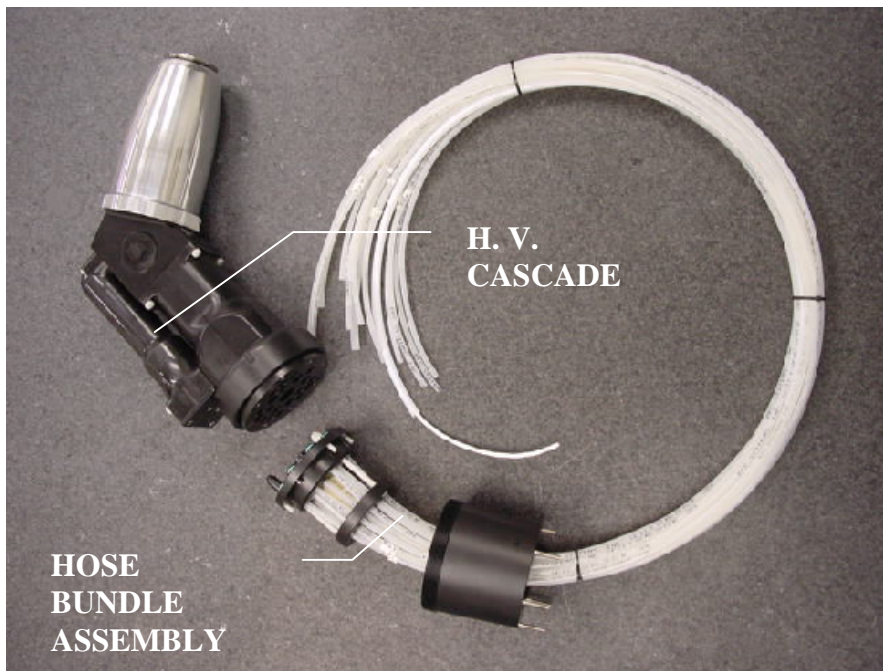

The hose bundle assembly is the collection of tubes and wires used to supply the atomizer assembly with the proper fluids and low voltage for operation. The tubing is offered in various sizes and materials to meet customer requirements. All of the hoses are attached to the atomizer assembly via push lock fittings and double Tekrez® seals.

3.2e 4x4 Card Cage

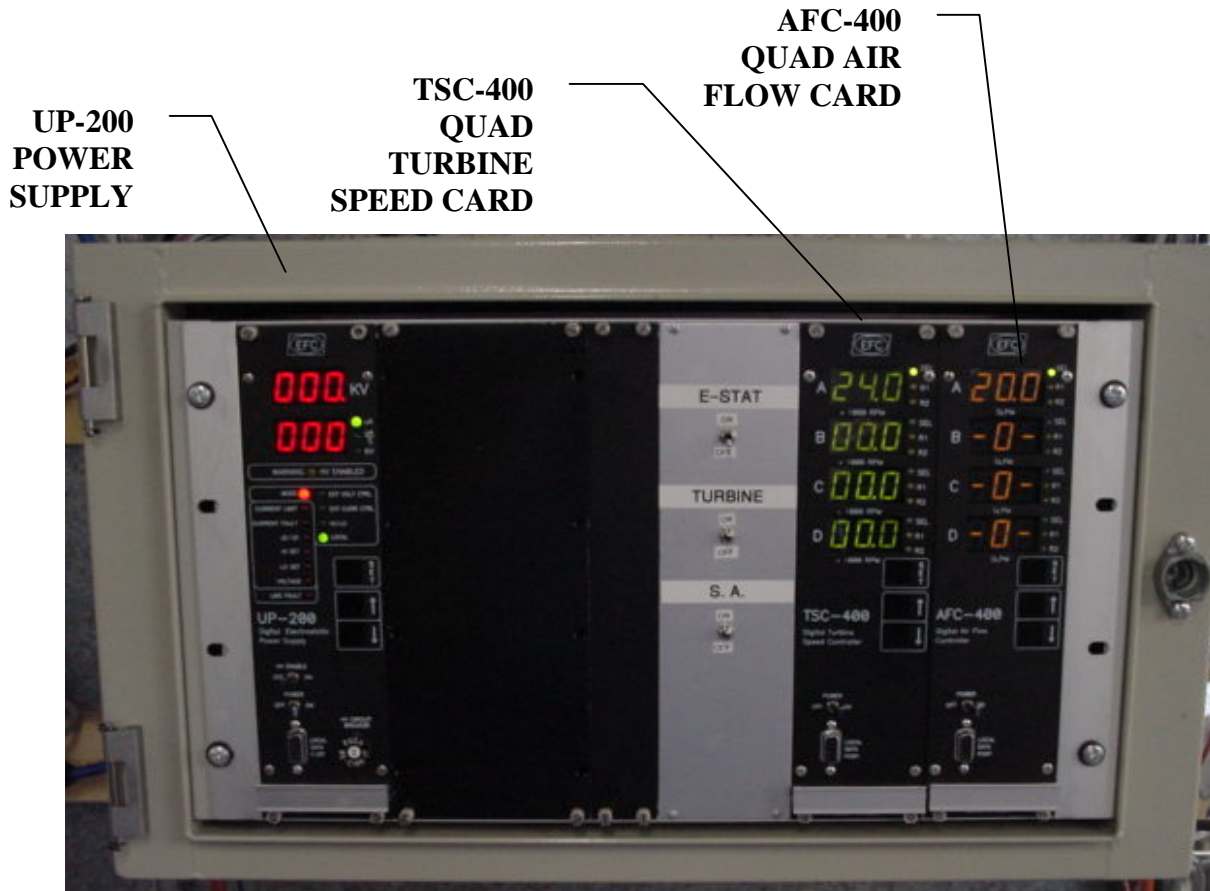

The EFC 4x4 Card cage is a pre-wired system that supports the PS-100, UP-100, UP-200, UP-500, TSC-400, FRC-400, AFC-400 products from EFC. The card cage and back plane can be designed to handle the following configurations:

- CB-1000 (Four UP-100/200/500s) or (Four PS-100s)
- CB-2000 (Four UP-100/200/500s, One TSC-400 / AFC-400 / FFC-200)
- CB-3000 (Four UP-100/200/500s, Two TSC-400 /AFC-400 / FFC-200)
- CB-4000 (Six UP-100/200/500s)
- CB-5000 (Six TSC-400 / AFC-400 / FFC-200)

This card cage is intended for professional installation by qualified personnel who are familiar with the installation of Electrostatic Power systems.

4.0 SAFE GUARDS

The EFC FS40R has numerous safety features built into the power supply (UP-200). The UP-200 incorporates state of the art safety features and fail-safes to provide for a safe operating environment. These include:

- Over voltage detection
- Over current detection
- Fast current slew rate detection and limiting
- Turn-on proximity detection
- Open and short line detection and protection
- Current limiting via voltage fold-back
- Voltage control 0 – 10 VDC
- Current control 4 – 20 mA

5.0 FINISHING CHARACTERISTICS

- Superior finish
- High transfer efficiency
- Improved atomization via serrated bell cup
- Uniform droplet size distribution
- Good metallic color match

6.0 TECHNICAL INFORMATION

- Bell Speed: 0 – 80,000 rpm
- Paint Flow: 50 – 1000 ccpm
- Viscosity: 10 – 60 sec Ford #4
- Voltage: 0 – 100,000 volts
- Current: 0 – 200 μ A
- Bell Cup: 65mm Titanium, Serrated
- Air Consumption: 10 – 30 SCFM
- Air Pressure: 90 psi